

# INSTALLATION MANUAL

## R-410A ZJ SERIES W/SIMPLICITY SE

15 - 25 Ton

60 Hertz



### TABLE OF CONTENTS

General .....	2	Outputs .....	31
Installation .....	5	Operation .....	9
Limitations .....	5	Optional BAS-Ready Economizer Power Exhaust Damper	
Location .....	7	Set Point Adjustment .....	35
Rigging And Handling .....	7	Optional Variable Air Volume (VAV) .....	35
Ductwork .....	12	Optional Hot Gas Bypass (HGBP) .....	36
Condensate Drain .....	13	Air Balance .....	46
Compressors .....	13	Sequence Of Operation .....	48
Filters .....	13	Cooling Sequence of Operation .....	48
Power And Control Wiring .....	14	Cooling Operation Errors .....	49
Field Installed Electric Heat Accessories .....	27	Electric Heating Sequence Of Operations .....	50
Optional Gas Heat .....	27	Electric Heat Operation Errors .....	50
Options/Accessories .....	29	Gas Heating Sequence Of Operations .....	51
Economizer Sequences .....	30	Gas Heating Operation Errors .....	52
Dry Bulb Changeover .....	30	Start-Up (Cooling) .....	53
Single Enthalpy Changeover .....	30	Start-Up (Gas Heat) .....	53
Dual Enthalpy Changeover .....	30	Checking Gas Heat Input .....	54
Auto .....	30	Charging The Unit .....	56
Free Cooling Operation .....	30	Simplicity™ SE (Smart Equipment) Firmware Version 3.	
Power Exhaust .....	31	Basic Unit Control Board Navigation Examples: .....	57
Setpoints .....	31	Start-Up Sheet .....	68
Inputs .....	31		

### LIST OF TABLES

1 ZJ180-300 Unit Limitations .....	7	15 Altitude/Temperature Correction Factors .....	38
2 Weights and Dimensions .....	8	16 Air Flow Performance - Side Duct Application .....	40
3 ZJ180-300 Unit Accessory Weights .....	9	17 Air Flow Performance - Bottom Duct Application .....	43
4 Utilities Entry .....	9	18 RPM Selection .....	46
5 Supply Fan VFD Weights, In Lbs. ....	9	19 Indoor Blower Specifications .....	46
6 ZJ180-300 Unit Clearances .....	11	20 Power Exhaust Specifications .....	46
7 Control Wire Sizes .....	15	21 Limit Control Setting .....	51
8 Electrical Data .....	16	22 Electric Heat Anticipator Setpoint .....	51
9 ZJ180-300 Physical Data .....	25	23 Gas Heat Limit Control Setting .....	53
10 Electric Heat Minimum Supply Air .....	27	24 Gas Heat Anticipator Setpoints .....	53
11 Gas Application Data .....	27	25 Gas Rate Cubic Feet Per Hour .....	54
12 Gas Pipe Sizing - Capacity of Pipe .....	28	26 Simplicity SE UCB Details .....	59
13 Gas Heat Minimum Supply Air .....	28	27 4-Stage Board .....	65
14 Simplicity SE Economizer Board Details .....	32		

### LIST OF FIGURES

1 ZJ180-300 Component Location .....	6	16 SE-ECO1001-0 Economizer Controller .....	32
2 Unit 4 Point Load Weight .....	8	17 Belt Adjustment .....	37
3 Unit 6 Point Load Weight .....	8	18 Altitude/Temperature Correction Factors .....	38
4 Center of Gravity .....	8	19 Pressure Drop Across A Dry Indoor Coil Vs. Supply Air CFM	
5 ZJ180-300 Unit Dimensions Front View .....	9	For All Unit Tonnages .....	47
6 ZJ180-300 Unit Dimensions Rear View .....	10	20 Gas Valve Piping .....	52
7 ZJ180-300 Unit Dimensions Rain Hood .....	11	21 Gas Valve and Controls .....	53
8 ZJ180-300 Roof Curb .....	12	22 Proper Pilot Flame Adjustment .....	55
9 Fixed Outdoor Air Damper .....	13	23 Typical Flame .....	55
10 Condensate Drain .....	13	24 Typical Gas Valve .....	55
11 Field Wiring Disconnect - Cooling Unit With/Without Electric		25 ZJ180 (15 Ton) Charging Chart .....	56
Heat .....	14	26 ZJ210 (17.5 Ton) Charging Chart .....	56
12 Typical Field Wiring 24 Volt Thermostat .....	15	27 ZJ240 (20 Ton) Charging Chart .....	56
13 External Supply Connection External Shut-Off .....	27	28 ZJ300 (25 Ton) Charging Chart .....	56
14 Bottom Supply Connection External Shut-Off .....	28	29 Unit Control Board .....	59
15 Vent and Combustion Air Hood .....	29	30 4-Stage Board .....	65

## General

YORK® Model ZJ units are either single package air conditions equipped with electric heaters (Field Installed Accessory Only), or single package gas-fired central heating furnaces with cooling unit. Both are designed for outdoor installation on a rooftop or slab.

The units are completely assembled on rigid, permanently attached base rails. All piping, refrigerant charge, and electrical wiring is factory installed and tested. The units require electric power, gas connection, duct connections, installation of combustion air inlet hood, flue gas outlet hoods and fixed outdoor air intake damper (units without economizer or motorized damper option only) at the point of installation.

The electric heater accessories have nickel-chrome elements and utilize single point power connection.

These gas-fired heaters have aluminized-steel or optional stainless steel, tubular heat exchangers with spark ignition with proven pilot. All gas heaters are shipped from the factory equipped for natural gas use, but can be field converted to L.P./Propane with Kit Model # 1NP0418. See Gas Heat Application Data Table.

### Safety Considerations

This is a safety alert symbol. When you see this symbol on labels or in manuals, be alert to the potential for personal injury.

Understand and pay particular attention the signal words **DANGER**, **WARNING** or **CAUTION**.

**DANGER** indicates an **imminently** hazardous situation, which, if not avoided, **will result in death or serious injury**.

**WARNING** indicates a **potentially** hazardous situation, which, if not avoided, **could result in death or serious injury**.

**CAUTION** indicates a potentially hazardous situation, which, if not avoided **may result in minor or moderate injury**. It is also used to alert against unsafe practices and hazards involving only property damage.

### **WARNING**

Improper installation may create a condition where the operation of the product could cause personal injury or property damage. Improper installation, adjustment, alteration, service or maintenance can cause injury or property damage. Refer to this manual for assistance or for additional information, consult a qualified contractor, installer or service agency.

### **CAUTION**

This product must be installed in strict compliance with the installation instructions and any applicable local, state and national codes including, but not limited to building, electrical, and mechanical codes.

### **WARNING**

Before performing service or maintenance operations on unit, turn off main power switch to unit. Electrical shock could cause personal injury. Improper installation, adjustment, alteration, service or maintenance can cause injury or property damage. Refer to this manual. For assistance or additional information consult a qualified installer, service agency or the gas supplier.

### **CAUTION**

This system uses R-410A Refrigerant which operates at higher pressures than R-22. No other refrigerant may be used in this system. Gage sets, hoses, refrigerant containers and recovery systems must be designed to handle R-410A. If you are unsure, consult the equipment manufacturer. Failure to use R-410A compatible servicing equipment may result in property damage or injury.

### **WARNING**

If the information in this manual is not followed exactly, a fire or explosion may result causing property damage, personal injury or loss of life.

Do not store or use gasoline or other flammable vapors and liquids in the vicinity of this or any other appliance.

#### WHAT TO DO IF YOU SMELL GAS:

- a. Do not try to light any appliance.
- b. Do not touch any electrical switch; do not use any phone in your building.
- c. Immediately call your gas supplier from a neighbor's phone. Follow the gas supplier's instructions.
- d. If you cannot reach your gas supplier, call the fire department.

Installation and service must be performed by a qualified installer, service agency or the gas supplier.

Due to system pressure, moving parts, and electrical components, installation and servicing of air conditioning equipment can be hazardous. Only qualified, trained service personnel should install, repair, or service this equipment.

Untrained personnel can perform basic maintenance functions of cleaning coils and filters and replacing filters.

Observe all precautions in the literature, labels, and tags accompanying the equipment whenever working on air conditioning equipment. Be sure to follow all other applicable safety precautions and codes including ANSI Z223.1 or CSA-B149.1- latest edition.

Wear safety glasses and work gloves. Use quenching cloth and have a fire extinguisher available during brazing operations.

### Inspection

As soon as a unit is received, it should be inspected for possible damage during transit. If damage is evident, the extent of the damage should be noted on the carrier's freight bill. A separate request for inspection by the carrier's agent should be made in writing.

### CAUTION

This product must be installed in strict compliance with the enclosed installation instructions and any applicable local, state and national codes including, but not limited to, building, electrical, and mechanical codes.

The furnace and its individual shut-off valve must be disconnected from the gas supply piping system during any pressure testing at pressures in excess of 1/2 PSIG.

Pressures greater than 1/2 PSIG will cause gas valve damage resulting in a hazardous condition. If it is subjected to a pressure greater than 1/2 PSIG, the gas valve must be replaced.

The furnace must be isolated from the gas supply piping system by closing its individual manual shut-off valve during any pressure testing of the gas supply piping system at test pressures equal to or less than 1/2 PSIG.

### Reference

Additional information is available in the following reference forms:

- Technical Guide - ZJ180-300, 5168277
- General Installation - ZJ180-300, 5168244
- Electric Heat Accessory Installation - 5128261
- SSE Control Quick Start Guide - 1136326

### Renewal Parts

Contact your local York® parts distribution center for authorized replacement parts.

### Approvals

Design certified by CSA as follows:

1. For use as a cooling only unit, cooling unit with supplemental electric heat or a forced air furnace.
2. For outdoor installation only.
3. For installation on combustible material.
4. For use with natural gas (convertible to LP with kit).

### CAUTION

This product must be installed in strict compliance with the enclosed installation instructions and any applicable local, state, and national codes including, but not limited to, building, electrical, and mechanical codes.

### WARNING

Improper installation may create a condition where the operation of the product could cause personal injury or property damage.

### CAUTION

This system uses R-410A Refrigerant which operates at higher pressures than R-22. No other refrigerant may be used in this system.

Nomenclature

15-25 Ton York® Model Number Nomenclature

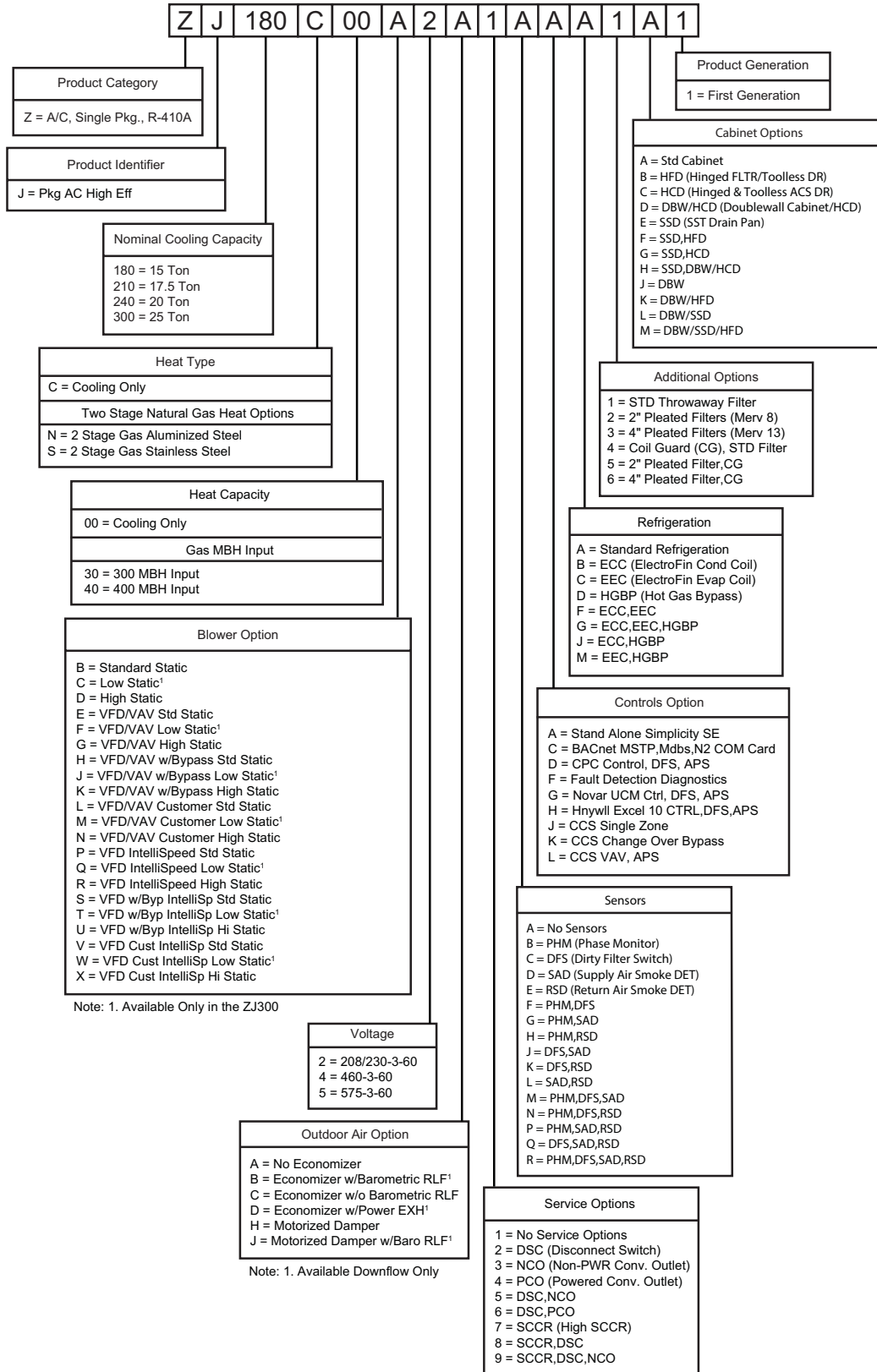

## Installation

### Installation Safety Information

Read these instructions before continuing this appliance installation. This is an outdoor combination heating and cooling unit. The installer must assure that these instructions are made available to the consumer and with instructions to retain them for future reference.

1. Refer to the unit rating plate for the approved type of gas for this product.
2. Install this unit only in a location and position as specified on Page 7 of these instructions.
3. Never test for gas leaks with an open flame. Use commercially available soap solution made specifically for the detection of leaks when checking all connections, as specified on Pages 5, 28 and 54 of these instructions.
4. Always install furnace to operate within the furnace's intended temperature-rise range with the duct system and within the allowable external static pressure range, as specified on the unit name/rating plate, specified on Page 27 of these instructions.
5. This equipment is not to be used for temporary heating of buildings or structures under construction.

### WARNING

#### FIRE OR EXPLOSION HAZARD

Failure to follow the safety warning exactly could result in serious injury, death or property damage.

Never test for gas leaks with an open flame. use a commercially available soap solution made specifically for the detection of leaks to check all connections. A fire or explosion may result causing property damage, personal injury or loss of life.

6. If a factory option convenience outlet is installed, the weatherproof outlet cover must be field installed. The cover shall be located in the unit control box. To install the cover, remove the shipping label covering the convenience outlet, follow the instructions on the back of the weatherproof cover box, and attach the cover to the unit using the (4) screws provided.

### CAUTION

208/230-3-60 and 380/415-3-50 units with factory installed Powered Convenience Outlet Option are wired for 230v and 415v power supply respectively. Change tap on transformer for 208-3-60 or 380-3-50 operation. See unit wiring diagram.

### Limitations

These units must be installed in accordance with the following:

#### In U.S.A.:

1. National Electrical Code, ANSI/NFPA No. 70 - Latest Edition
2. National Fuel Gas Code, ANSI Z223.1 - Latest Edition
3. Gas-Fired Central Furnace Standard, ANSI Z21.47a. - Latest Edition
4. Local building codes, and
5. Local gas utility requirements

#### In Canada:

1. Canadian Electrical Code, CSA C22.1
2. Installation Codes, CSA - B149.1.
3. Local plumbing and waste water codes, and
4. Other applicable local codes.

Refer to unit application data found in this document.

After installation, gas fired units must be adjusted to obtain a temperature rise within the range specified on the unit rating plate.

If components are to be added to a unit to meet local codes, they are to be installed at the dealer's and/or customer's expense.

Size of unit for proposed installation should be based on heat loss/heat gain calculation made according to the methods of Air Conditioning Contractors of America (ACCA).

This furnace is not to be used for temporary heating of buildings or structures under construction.

### CAUTION

The SE control board used in this product will effectively operate the cooling system down to 0°F when this product is applied in a comfort cooling application for people. An economizer is typically included in this type of application. When applying this product for process cooling applications (computer rooms, switchgear, etc.), please reference applications bulletin AE-011-07 or call the applications department for Unitary Products @ 1-877-UPG-SERV for guidance. Additional accessories may be needed for stable operation at temperatures below 30°F.

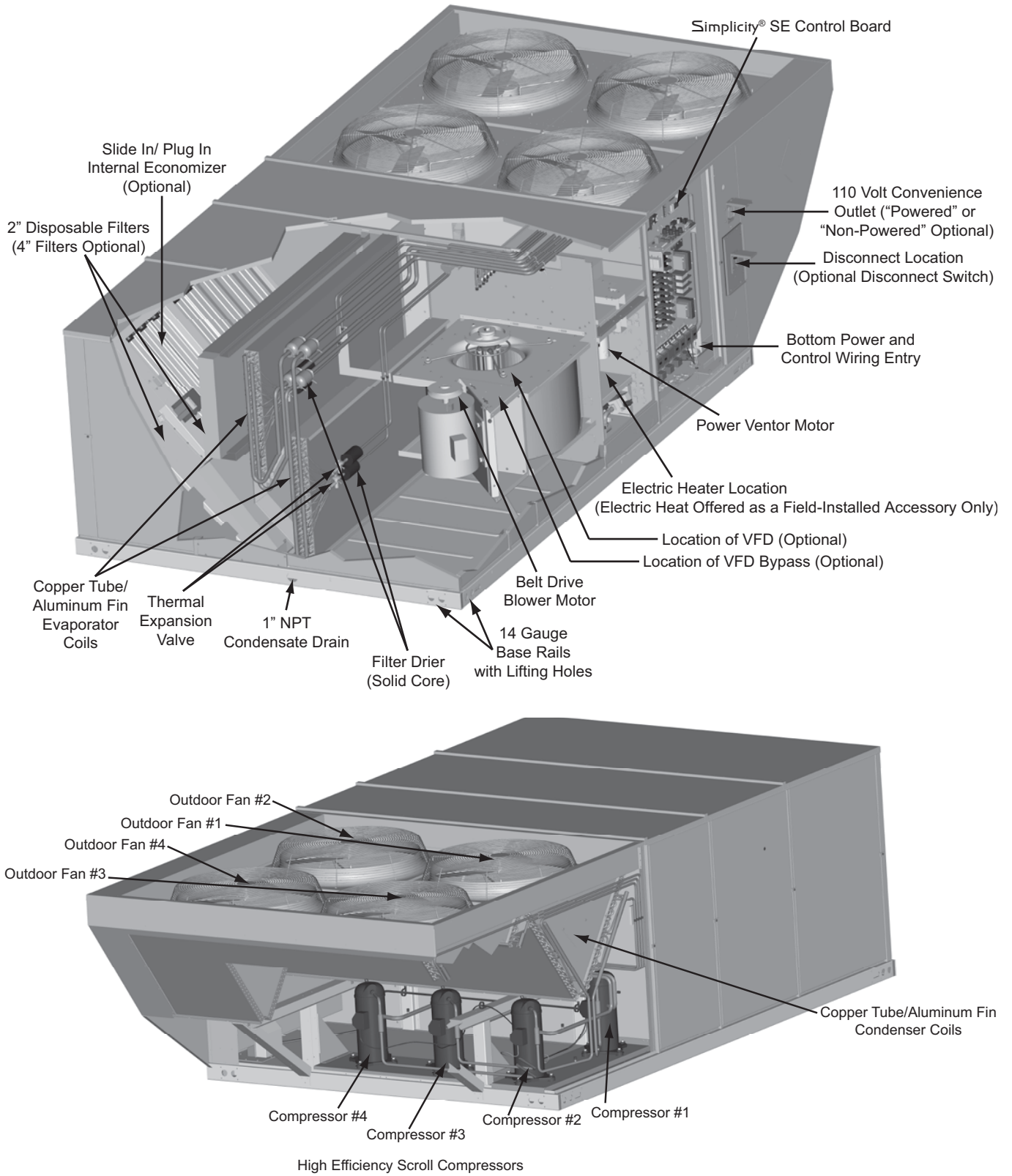

**Figure 1: ZJ180-300 Component Location**

Table 1: ZJ180-300 Unit Limitations

Size (Tons)	Unit Voltage	Unit Limitations		
		Applied Voltage		Outdoor DB Temp
		Min	Max	Max (°F)
180 (15)	208/230-3-60	187	252	125
	460-3-60	432	504	125
	575-3-60	540	630	125
210 (17.5)	208/230-3-60	187	252	125
	460-3-60	432	504	125
	575-3-60	540	630	125
240 (20)	208/230-3-60	187	252	125
	460-3-60	432	504	125
	575-3-60	540	630	125
300 (25)	208/230-3-60	187	252	125
	460-3-60	432	504	125
	575-3-60	540	630	125

### Location

Use the following guidelines to select a suitable location for these units:

- Unit is designed for *outdoor installation only*.
- Condenser coils must have an unlimited supply of air. Where a choice of location is possible, position the unit on either north or east side of building.
- Suitable for mounting on roof curb.
- For ground level installation, use a level concrete slab with a minimum thickness of 4 inches. The length and width should be at least 6 inches greater than the unit base rails. Do not tie slab to the building foundation.
- Roof structures must be able to support the weight of the unit and its options/accessories. Unit must be installed on a solid, level roof curb or appropriate angle iron frame.
- Maintain level tolerance to 1/2" across the entire width and length of unit.

### WARNING

Excessive exposure of this furnace to contaminated combustion air may result in equipment damage or personal injury. Typical contaminants include: permanent wave solution, chlorinated waxes and cleaners, chlorine based swimming pool chemicals, water softening chemicals, carbon tetrachloride, Halogen type refrigerants, cleaning solvents (e.g. perchloroethylene), printing inks, paint removers, varnishes, hydrochloric acid, cements and glues, antistatic fabric softeners for clothes dryers, masonry acid washing materials.

### Clearances

All units require particular clearances for proper operation and service. Installer must make provisions for adequate combustion and ventilation air in accordance with section 5.3 of Air for Combustion and Ventilation of the National Fuel Gas Code, ANSI Z223.1 – Latest Edition (in U.S.A.), or Sections 7.2, 7.3, or 7.4 of Gas Installation Codes, CSA-B149.1 (in Canada) - Latest Edition, and/or applicable provisions of the local building codes. Refer to Table 6 for clearances required for combustible construction, servicing, and proper unit operation.

### WARNING

Do not permit overhanging structures or shrubs to obstruct condenser air discharge outlet, combustion air inlet or vent outlets.

### Rigging And Handling

Exercise care when moving the unit. Do not remove any packaging until the unit is near the place of installation. Rig the unit by attaching chain or cable slings to the lifting holes provided in the base rails. Spreader bars, whose length exceeds the largest dimension across the unit, **MUST** be used across the top of the unit.

### CAUTION

If a unit is to be installed on a roof curb other than a York® roof curb, gasketing must be applied to all surfaces that come in contact with the unit underside.

**CAUTION**

Before lifting, make sure the unit weight is distributed equally on the rigging cables so it will lift evenly.

Units may be moved or lifted with a forklift, from the side only, providing an accessory skid is used.

**LENGTH OF FORKS MUST BE A MINIMUM OF 90 INCHES.**

**CAUTION**

All panels must be secured in place when the unit is lifted.  
The condenser coils should be protected from rigging cable damage with plywood or other suitable material.

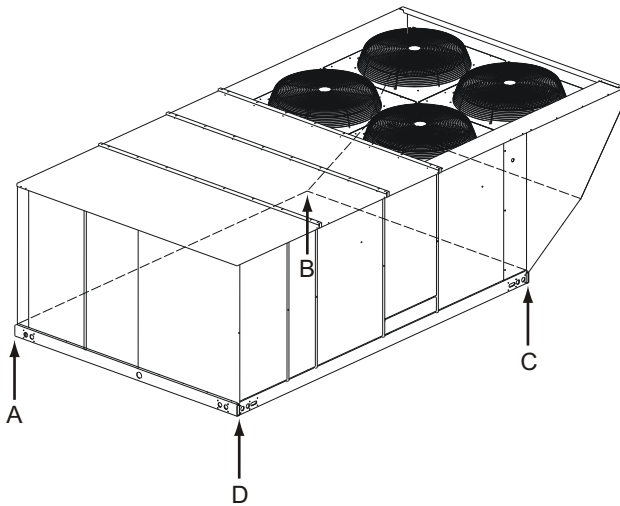

**Figure 2: Unit 4 Point Load Weight**

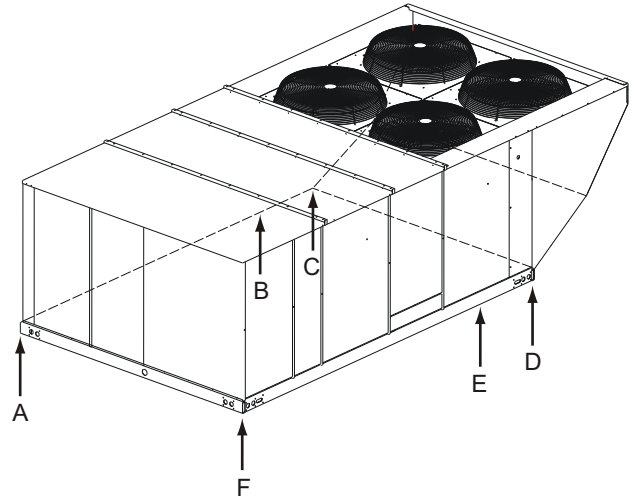

**Figure 3: Unit 6 Point Load Weight**

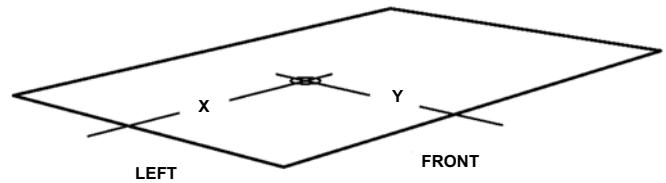

**Figure 4: Center of Gravity**

**Table 2: Weights and Dimensions**

Size (Tons)	Weight (lbs.)		Center of Gravity		4 Point Load Location (lbs.)				6 Point Load Location (lbs.)					
	Shipping	Operating	X	Y	A	B	C	D	A	B	C	D	E	F
180 (15)	2614	2609	85.25	44	467	781	852	510	287	392	568	620	428	313
210 (17.5)	2670	2665	85.25	44	477	797	870	520	293	401	580	633	437	320
240 (20)	2702	2697	85.05	44	485	805	878	529	298	406	585	638	443	326
300 (25)	2788	2783	85.25	44	498	833	908	544	306	419	606	661	457	334



**Table 3: ZJ180-300 Unit Accessory Weights**

Unit Accessory	Weight (lbs.)	
	Shipping	Operating
Economizer	165	160
Power Exhaust	90	85
Electric Heat <sup>1</sup>	40	40
Gas Heat <sup>2</sup>	240	240
Double Wall	260	260
Motorized Damper	150	150
Barometric Damper	50	45
Econ./Motorized Damper Rain Hood	60	55
Econ./Power Exhaust Rain Hood	95	90
Wood Skid	220	220
Roof Curb	190	185
Hot Gas Bypass	10	10
Supply Fan VFD	See Table 5	

- Weight given is for the maximum heater size available (72kW).
- Weight given is for the maximum number of tube heat exchangers available (8 tube).

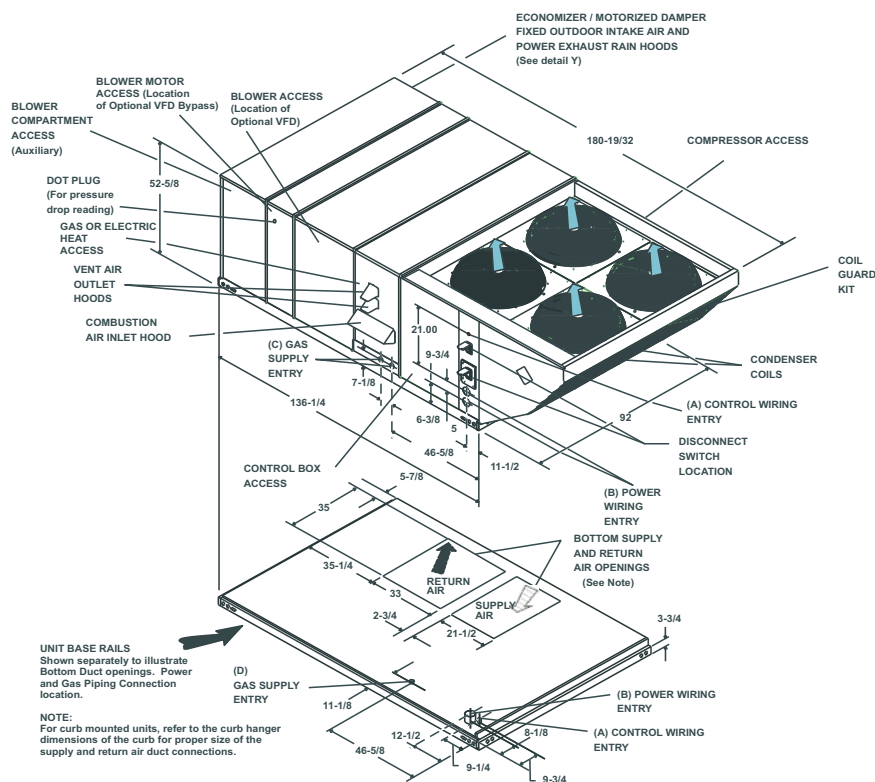

**Figure 5: ZJ180-300 Unit Dimensions Front View**

**Table 4: Utilities Entry**

Hole	Opening Size Diameter	Used For	
A	1-1/8" KO	Control Wiring	Front
	3/4" NPS (Fem.)		Bottom
B	3-5/8" KO	Power Wiring	Front
	3" NPS (Fem.)		Bottom
C	2-3/8" KO	Gas Piping (Front) <sup>1</sup>	
D	1-11/16" Hole	Gas Piping (Bottom) <sup>1,2</sup>	

- One-inch Gas Piping NPT Required.
- Opening in the bottom to the unit can be located by the slice in the insulation.

**Note:** All entry holes should be sealed to prevent rain water entry into building.

**Table 5: Supply Fan VFD Weights, In Lbs.**

Supply Fan Motor	230V	460V	575V
<b>W/O Manual Bypass</b>			
5.0 hp	25	25	30
7.5 hp	30	30	30
10.0 hp	30	30	35
15.0 hp	30	30	40
<b>W/Manual Bypass</b>			
5.0 hp	30	30	35
7.5 hp	35	35	35
10.0 hp	35	35	40
15.0 hp	40	35	45

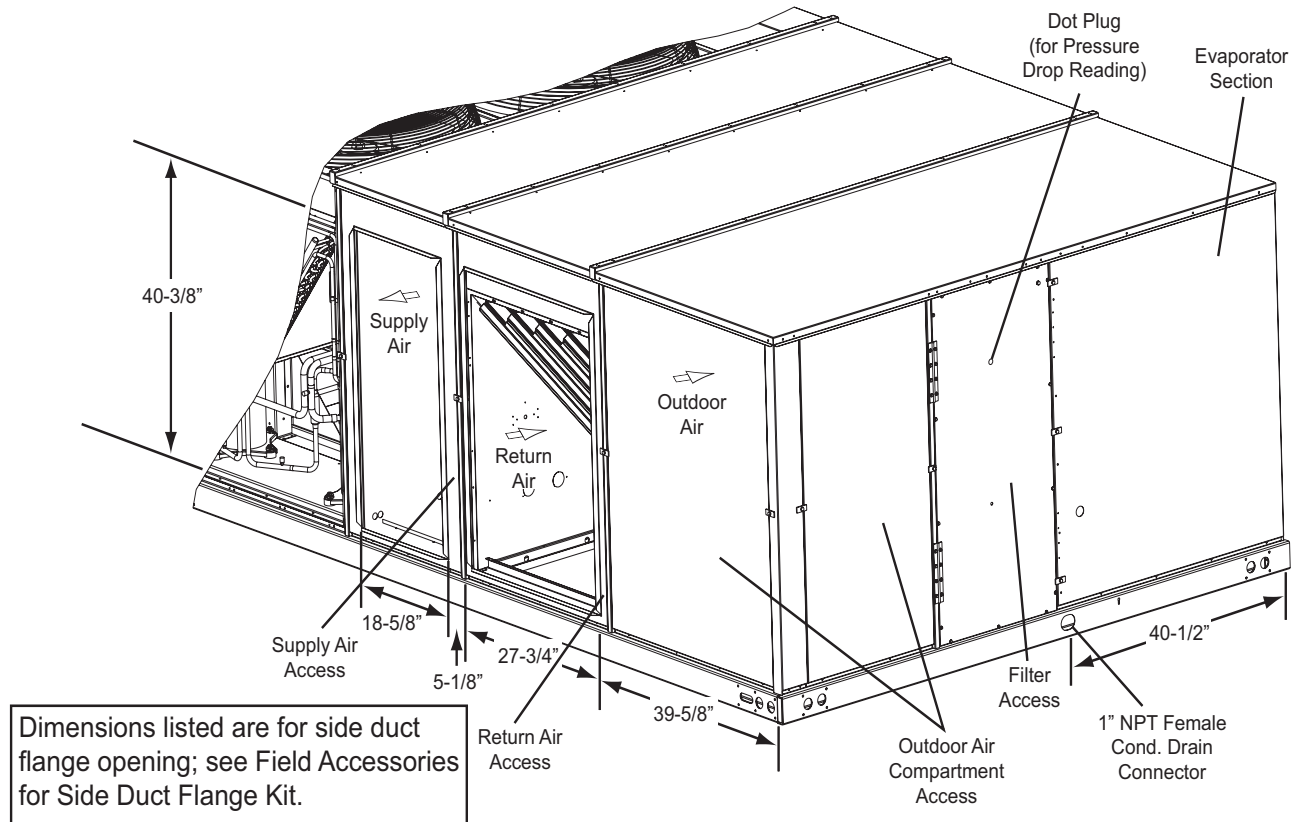

**Figure 6: ZJ180-300 Unit Dimensions Rear View**

**NOTE:** Units are shipped with the bottom duct openings covered. An accessory flange kit is available for connecting side ducts.

**For bottom duct applications:**

1. Remove the side panels from the supply and return air compartments to gain access to the bottom supply and return air duct covers.
2. Remove and discard the bottom duct covers. Duct openings are closed with sheet metal covers except when the unit includes a power exhaust option. The covering consists of a heavy black paper composition.
3. Replace the side supply and return air compartment panels.

**For side duct applications:**

1. Replace the side panels on the supply and return air compartments with the accessory flange kit panels.
2. Connect ductwork to the flanges on those panels.

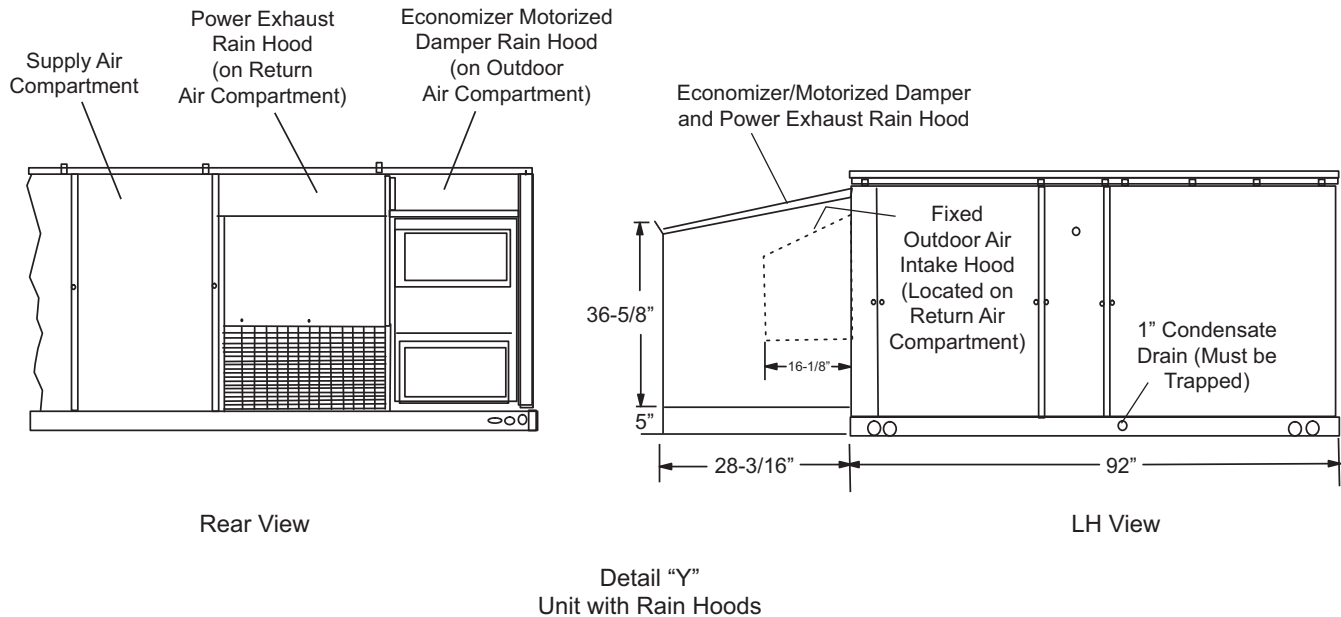

**Figure 7: ZJ180-300 Unit Dimensions Rain Hood**

**Table 6: ZJ180-300 Unit Clearances**

Direction	Distance (in.)	Direction	Distance (in.)
Top <sup>1</sup>	72 With 36 Maximum Horizontal Overhang (For Condenser Air Discharge)	Right	36
Front	36	Bottom <sup>2</sup>	0
Rear	24 (W/O Economizer)	Left	24 (W/O Economizer)
	49 (W/Economizer)		36 (W/Economizer) <sup>3</sup>

- Units must be installed outdoors. Over hanging structure or shrubs should not obscure condenser air discharge outlet.
- Units may be installed on combustible floors made from wood or class A, B or C roof covering materials.
- If economizer is factory installed, the unassembled rain hood must be removed from its side along position in front of the evaporator coil, or in the outdoor air compartment, prior to final installation.

**Note: ELEC/ELEC Models:** Units and ductwork are approved for zero clearance to combustible material when equipped with electric heaters.

**GAS/ELEC Models:** A 1" clearance must be provided between any combustible material and the supply air ductwork for a distance of 3 feet from the unit.

The products of combustion must not be allowed to accumulate within a confined space and recirculate.

Locate unit so that the vent air outlet hood is at least:

- Three (3) feet above any force air inlet located within 10 horizontal feet (excluding those integral to the unit).
- Four (4) feet below, four horizontal feet from, or one foot above any door or gravity air inlet into the building.
- Four (4) feet from electric and gas meters, regulators and relief equipment.

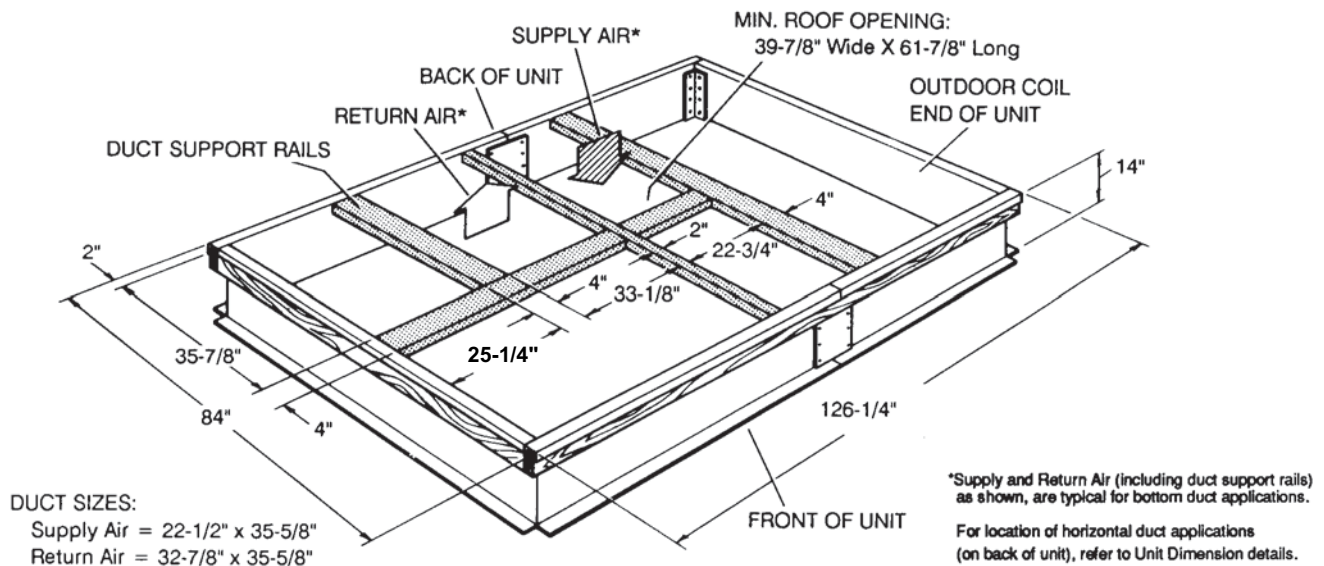

**Figure 8: ZJ180-300 Roof Curb**

### Ductwork

Ductwork should be designed and sized according to the methods in Manual D of the Air Conditioning Contractors of America (ACCA) or as recommended by any other recognized authority such as ASHRAE or SMACNA.

A closed return duct system should be used. This will not preclude use of economizers or outdoor fresh air intake. The supply and return air duct connections at the unit should be made with flexible joints to minimize noise.

The supply and return air duct systems should be designed for the CFM and static pressure requirements of the job. They should NOT be sized to match the dimensions of the duct connections on the unit.

Refer to Figure 5 for bottom air duct openings. Refer to Figure 6 for side air duct openings.

**NOTE:** It is recommended that, in Canada, the outlet duct be provided with a removable access panel. It is recommended that this opening be accessible when the unit is installed in service, and of a size such that smoke or reflected light may be observed inside the casing to indicate the presence of leaks in the heat exchanger. The cover should be attached in a manner adequate to prevent leakage.

### Fixed Outdoor Air Intake Damper

This damper is shipped inside the return air compartment. It is completely assembled and ready for installation. A damper baffle inside of the hood is adjustable to provide variable amounts of outdoor air intake on units that are not provided with an economizer or a motorized damper option. Refer to the Fixed Outdoor Damper Figure 9.

Gasketing and mounting screws are provided in a parts bag attached to the hood assembly. Apply gasketing to the three flange surfaces on the hood prior to installing the hood. Extend gasketing 1/4 inch beyond the top and bottom of the two side flanges to insure adequate sealing.

Adjusting the damper to the desired air flow may be done before mounting the hood into position or after installation by removing the front hood panel or the screen on the bottom of the hood. Damper baffle in position 1 will allow approximately 10% outdoor air flow, position 2 approximately 15% and, to allow approximately 25%, remove the damper baffle.

On units with bottom return air application install the damper assembly over the opening in the side return air access panel. Remove and discard the opening cover and the covering over the hood mounting holes (used for shipping) before installing. Secure with the screws provided.

On units with side return air applications, install the damper assembly on the return air ductwork as close to the unit as possible. Cut an opening 16 inches high by 18 inches wide in the ductwork to accommodate the damper. Using the holes in the hood flanges as a template, drill 9/64 inch diameter (#26 drill) holes into the ductwork and secure with the screws provided.

### CAUTION

If outdoor air intake will not be required on units with bottom return air applications, the damper assembly should still be mounted on the side return air access panel, per the instructions above, to insure moisture is not drawn into the unit during operation. The covering over the mounting holes only need be removed. Do not remove the opening cover.

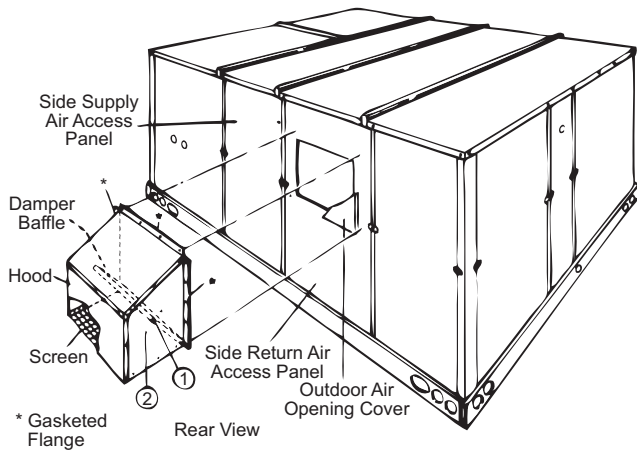
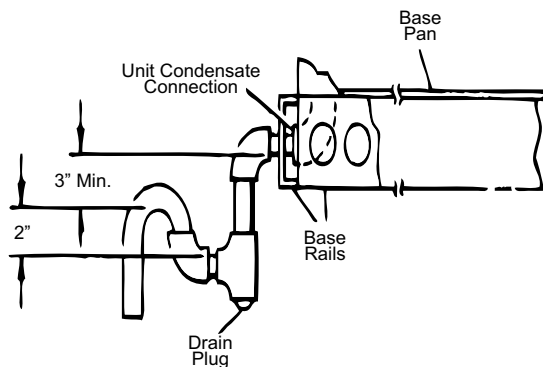

**Figure 9: Fixed Outdoor Air Damper**

### Condensate Drain

Plumbing must conform to local codes. Use a sealing compound on male pipe threads. Install a condensate drain line from the one-inch NPT female connection on the unit to an open drain.

**NOTE:** The condensate drain operates in a negative pressure in the cabinet. The condensate drain line **MUST** be trapped to provide proper drainage. See Figure 10.



**Figure 10: Condensate Drain**

### Compressors

The scroll compressor used in this product is specifically designed to operate with R-410A Refrigerant and cannot be interchanged.

#### CAUTION

This system uses R-410A Refrigerant which operates at higher pressures than R-22. No other refrigerant may be used in this system.

The compressor also uses a polyolester (POE oil), Mobil 3MA POE. This oil is extremely hygroscopic, meaning it absorbs water readily. POE oil can absorb 15 times as much water as other oils designed for HCFC and CFC refrigerants. Take all necessary precautions to avoid exposure of the oil to the atmosphere.

#### CAUTION

Do not leave the system open to the atmosphere. Unit damage could occur due to moisture being absorbed by the **POE oil** in the system. This type of oil is highly susceptible to moisture absorption

POE (polyolester) compressor lubricants are known to cause long term damage to some synthetic roofing materials.

#### CAUTION

Exposure, even if immediately cleaned up, may cause embrittlement (leading to cracking) to occur in one year or more. When performing any service that may risk exposure of compressor oil to the roof, take precautions to protect roofing.

Procedures which risk oil leakage include, but are not limited to, compressor replacement, repairing refrigerant leaks, replacing refrigerant components such as filter drier, pressure switch, metering device or coil.

Units are shipped with compressor mountings which are factory-adjusted and ready for operation.

#### CAUTION

Do not loosen compressor mounting bolts.

### Filters

Two-inch filters are supplied with each unit, but units can be converted easily to four-inch filters. Filters must always be installed ahead of the evaporator coil and must be kept clean or replaced with same size and type. Dirty filters will reduce the capacity of the unit and will result in frosted coils or safety shutdown. Minimum filter area and required sizes are shown in Physical Data Table 9.

#### CAUTION

Make sure that panel latches are properly positioned on the unit to maintain an airtight seal.

### Power And Control Wiring

Field wiring to the unit, fuses, and disconnects must conform to provisions of National Electrical Code (NEC), ANSI/NFPA No. 70 – Latest Edition (in U.S.A.), current Canadian Electrical Code C221, and/or local ordinances. The unit must be electrically grounded in accordance with NEC and CEC as specified above and/or local codes.

Voltage tolerances which must be maintained at the compressor terminals during starting and running conditions are indicated on the unit Rating Plate and Table 1.

#### CAUTION

208/230-3-60 and 380/415-3-50 units control transformers are factory wired for 230v and 415v power supply respectively. Change tap on transformer for 208-3-60 or 380-3-50 operation. See unit wiring diagram.

The internal wiring harnesses furnished with this unit are an integral part of the design certified unit. Field alteration to comply with electrical codes should not be required. If any of the wire supplied with the unit must be replaced, replacement wire must be of the type shown on the wiring diagram and the same minimum gauge as the replaced wire.

A disconnect must be utilized for these units. Factory installed disconnects are available. If installing a disconnect (field supplied or York International® supplied accessory), refer to Figure 1 for the recommended mounting location.

#### CAUTION

Avoid damage to internal components if drilling holes for disconnect mounting.

**NOTE:** Since not all local codes allow the mounting of a disconnect on the unit, please confirm compliance with local code before mounting a disconnect on the unit.

Electrical line must be sized properly to carry the load. USE COPPER CONDUCTORS ONLY. Each unit must be wired with a separate branch circuit fed directly from the meter panel and properly fused.

Refer to Figures 11 and 12 for typical field wiring and to the appropriate unit wiring diagram mounted inside control doors for control circuit and power wiring information.

#### CAUTION

When connecting electrical power and control wiring to the unit, water-proof connectors must be used so that water or moisture cannot be drawn into the unit during normal operation. The above water-proofing conditions will also apply when installing a field supplied disconnect switch.

### Power Wiring Detail

Units are factory wired for the voltage shown on the unit nameplate. Refer to Electrical Data Table 8 to size power wiring, fuses, and disconnect switch.

Power wiring is brought into the unit through the side of the unit or the basepan inside the curb.

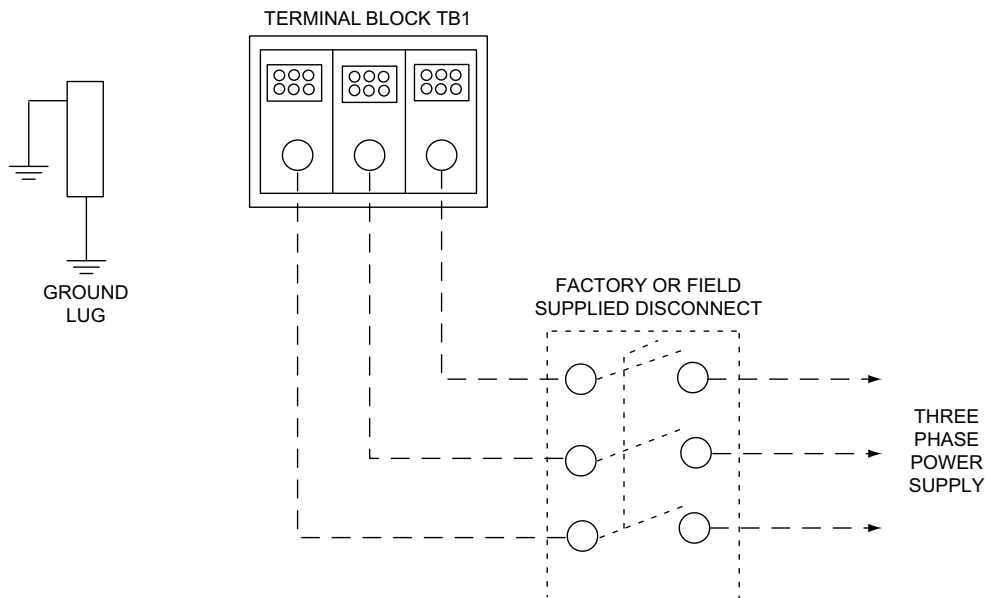

Figure 11: Field Wiring Disconnect - Cooling Unit With/Without Electric Heat

### Thermostat Wiring

The thermostat should be located on an inside wall approximately 56 inch above the floor where it will not be subject to drafts, sun exposure or heat from electrical fixtures or appliances. Follow the manufacturer's instructions enclosed with thermostat for general installation procedure. Seven (7) color-coded, insulated wires should be used to connect the thermostat to the unit. Refer to Table 7 for control wire sizing and maximum length.

### Space Sensor

The space sensor, if used, should be located on an inside wall approximately 56 inches above the floor where it will not be subject to drafts, sun exposure or heat from electrical fixtures or appliances. Follow manufacturer's instructions enclosed with sensor for general installation procedure.

**Table 7: Control Wire Sizes**

Wire Size	Maximum Length <sup>1</sup>
18 AWG	150 Feet

1. From the unit to the thermostat and back to the unit.

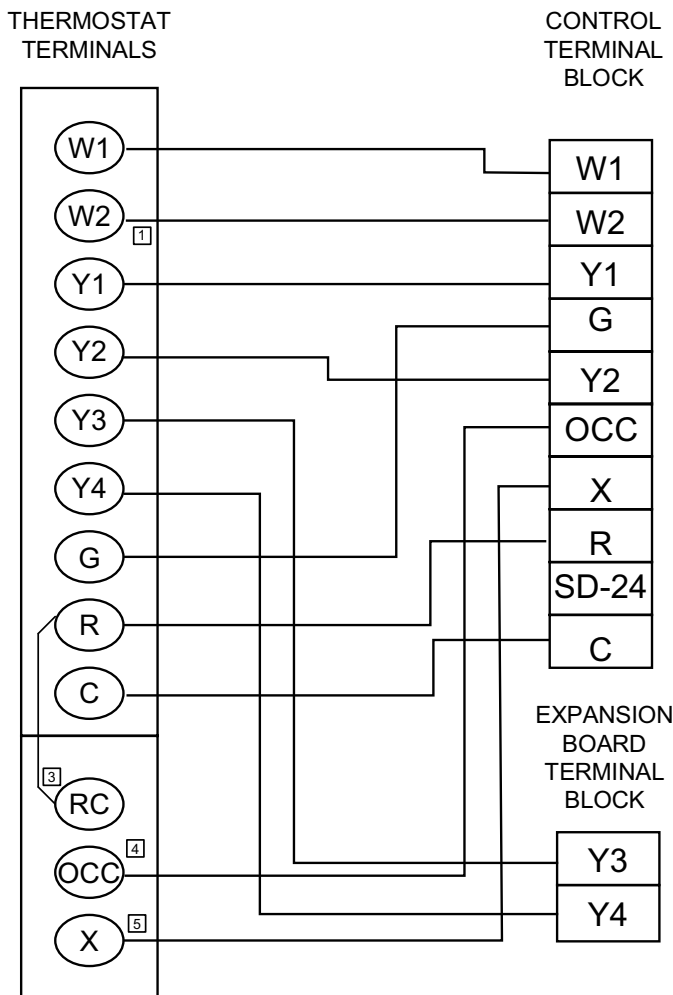

TERMINALS ON A LIMITED NUMBER OF THERMOSTATS

- 1 Second stage heating not required on single stage heating units.
- 2 Jumper is required if there is no Smoke Detector circuit.
- 3 Jumper is required for any combination of R, RC, or RH.
- 4 OCC is an output from the thermostat to indicate the Occupied condition.
- 5 X is an input to the thermostat to display Error Status conditions.

**⚠ CAUTION**

208/230-3-60 and 380/415-3-50 units control transformers are factory wired for 230v and 415v power supply respectively. Change tap on transformer for 208-3-60 or 380-3-50 operation. See unit wiring diagram.

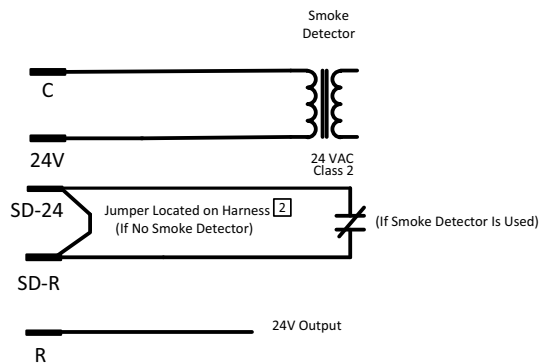

**Figure 12: Typical Field Wiring 24 Volt Thermostat**

**Table 8: Electrical Data**  
**ZJ180-300 - Standard Drive Without Powered Convenience Outlet**

Size (Tons)	Volt	Compressors (each)			OD Fan Motors (each)	Supply Blower Motor	Pwr Conv Outlet	Electric Heat (Field Installed Accessory Only)				MCA <sup>1</sup> (Amps)	Max Fuse <sup>2</sup> / Breaker <sup>3</sup> Size (Amps)
		RLA	LRA	MCC	FLA	FLA	FLA	Model	kW	Stages	Amps		
180 (15)	208-3-60	13.1	83.1	20.5	2.1	13.5	0	NONE	-	-	-	77.7	90
								E18	13.5	1	37.5	77.7	90
								E36	27	2	74.9	110.6	125
								E54	40.6	2	112.7	157.7	175
	230-3-60	13.1	83.1	20.5	2.1	13	0	NONE	-	-	-	77.1	90
								E18	18	1	43.3	77.1	90
								E36	36	2	86.6	124.5	125
								E54	54	2	129.9	146.2	175
	460-3-60	6.1	41	9.5	1.26	6.5	0	NONE	-	-	-	37.6	40
								E18	18	1	21.7	37.6	40
								E36	36	2	43.3	62.3	70
								E54	54	2	65	73.1	80
	575-3-60	4.4	33	6.8	0.66	5.2	0	NONE	-	-	-	26.7	30
								E18	18	1	17.3	28.2	30
								E36	36	2	34.6	49.8	50
								E54	54	2	52	58.5	70
210 (17.5)	208-3-60	14.5	98	22.6	2.1	13.5	0	NONE	-	-	-	83.5	90
								E18	13.5	1	37.5	83.5	90
								E36	27	2	74.9	110.6	125
								E54	40.6	2	112.7	157.7	175
	230-3-60	14.5	98	22.6	2.1	13	0	NONE	-	-	-	83	90
								E18	18	1	43.3	83	90
								E36	36	2	86.6	124.5	125
								E54	54	2	129.9	146.2	175
	460-3-60	6.3	55	9.9	1.26	6.5	0	NONE	-	-	-	38.4	40
								E18	18	1	21.7	38.4	40
								E36	36	2	43.3	62.3	70
								E54	54	2	65	73.1	80
	575-3-60	6	41	9.4	0.66	5.2	0	NONE	-	-	-	33.3	35
								E18	18	1	17.3	33.3	35
								E36	36	2	34.6	49.8	50
								E54	54	2	52	58.5	70
240 (20)	208-3-60	15.6	110	24.4	2.2	13.5	0	NONE	-	-	-	88.6	100
								E18	13.5	1	37.5	88.6	100
								E36	27	2	74.9	110.6	125
								E54	40.6	2	112.7	157.7	175
	230-3-60	15.6	110	24.4	2.2	13	0	NONE	-	-	-	88.1	100
								E18	18	1	43.3	88.1	100
								E36	36	2	86.6	124.5	125
								E54	54	2	129.9	146.2	175
	460-3-60	7.8	52	12.1	1.1	6.5	0	NONE	-	-	-	44.1	50
								E18	18	1	21.7	44.1	50
								E36	36	2	43.3	62.3	70
								E54	54	2	65	73.1	80
	575-3-60	5.8	38.9	9.1	0.9	5.2	0	NONE	-	-	-	33.5	35
								E18	18	1	17.3	33.5	35
								E36	36	2	34.6	49.8	50
								E54	54	2	52	58.5	70



## ZJ180-300 - Standard Drive Without Powered Convenience Outlet (Continued)

Size (Tons)	Volt	Compressors (each)			OD Fan Motors (each)	Supply Blower Motor	Pwr Conv Outlet	Electric Heat (Field Installed Accessory Only)				MCA <sup>1</sup> (Amps)	Max Fuse <sup>2</sup> / Breaker <sup>3</sup> Size (Amps)
		RLA	LRA	MCC	FLA	FLA	FLA	Model	kW	Stages	Amps		
300 (25)	208-3-60	22.4	149	35	2.2	26	0	NONE	-	-	-	130.9	150
								E18	13.5	1	37.5	130.9	150
								E36	27	2	74.9	130.9	150
								E54	40.6	2	112.7	173.4	175
								E72	54.1	2	150.2	182.7	200
	230-3-60	22.4	149	35	2.2	25	0	NONE	-	-	-	129.7	150
								E18	18	1	43.3	129.7	150
								E36	36	2	86.6	139.5	150
								E54	54	2	129.9	161.2	175
								E72	72	2	173.2	204.5	225
	460-3-60	10.6	75	16.5	1.1	12.5	0	NONE	-	-	-	62.4	70
								E18	18	1	21.7	62.4	70
								E36	36	2	43.3	69.8	70
								E54	54	2	65	80.6	90
								E72	72	2	86.6	102.2	110
	575-3-60	7.7	54	12	0.9	10	0	NONE	-	-	-	46.9	50
								E18	18	1	17.3	46.9	50
								E36	36	2	34.6	55.8	60
								E54	54	2	52	64.5	70
								E72	72	2	69.3	81.8	90

1. Minimum Circuit Ampacity.
2. Dual Element, Time Delay Type.
3. HACR type per NEC.

**ZJ180-300 - Standard Drive With Powered Convenience Outlet**

Size (Tons)	Volt	Compressors (each)			OD Fan Motors (each)	Supply Blower Motor	Pwr Conv Outlet	Electric Heat (Field Installed Accessory Only)				MCA <sup>1</sup> (Amps)	Max Fuse <sup>2</sup> / Breaker <sup>3</sup> Size (Amps)
		RLA	LRA	MCC	FLA	FLA	FLA	Model	kW	Stages	Amps		
180 (15)	208-3-60	13.1	83.1	20.5	2.1	13.5	10	NONE	-	-	-	87.7	100
								E18	13.5	1	37.5	87.7	100
								E36	27	2	74.9	123.1	125
								E54	40.6	2	112.7	170.2	175
	230-3-60	13.1	83.1	20.5	2.1	13	10	NONE	-	-	-	87.1	100
								E18	18	1	43.3	87.1	100
								E36	36	2	86.6	137	150
								E54	54	2	129.9	158.7	175
	460-3-60	6.1	41	9.5	1.26	6.5	5	NONE	-	-	-	42.6	45
								E18	18	1	21.7	42.6	45
								E36	36	2	43.3	68.5	70
								E54	54	2	65	79.3	90
	575-3-60	4.4	33	6.8	0.66	5.2	4	NONE	-	-	-	30.7	35
								E18	18	1	17.3	33.2	35
								E36	36	2	34.6	54.8	60
								E54	54	2	52	63.5	70
210 (17.5)	208-3-60	14.5	98	22.6	2.1	13.5	10	NONE	-	-	-	93.5	100
								E18	13.5	1	37.5	93.5	100
								E36	27	2	74.9	123.1	125
								E54	40.6	2	112.7	170.2	175
	230-3-60	14.5	98	22.6	2.1	13	10	NONE	-	-	-	93	100
								E18	18	1	43.3	93	100
								E36	36	2	86.6	137	150
								E54	54	2	129.9	158.7	175
	460-3-60	6.3	55	9.9	1.26	6.5	5	NONE	-	-	-	43.4	45
								E18	18	1	21.7	43.4	45
								E36	36	2	43.3	68.5	70
								E54	54	2	65	79.3	90
	575-3-60	6	41	9.4	0.66	5.2	4	NONE	-	-	-	37.3	40
								E18	18	1	17.3	37.3	40
								E36	36	2	34.6	54.8	60
								E54	54	2	52	63.5	70
240 (20)	208-3-60	15.6	110	24.4	2.2	13.5	10	NONE	-	-	-	98.6	110
								E18	13.5	1	37.5	98.6	110
								E36	27	2	74.9	123.1	125
								E54	40.6	2	112.7	170.2	175
	230-3-60	15.6	110	24.4	2.2	13	10	NONE	-	-	-	98.1	110
								E18	18	1	43.3	98.1	110
								E36	36	2	86.6	137	150
								E54	54	2	129.9	158.7	175
	460-3-60	7.8	52	12.1	1.1	6.5	5	NONE	-	-	-	49.1	50
								E18	18	1	21.7	49.1	50
								E36	36	2	43.3	68.5	70
								E54	54	2	65	79.3	90
	575-3-60	5.8	38.9	9.1	0.9	5.2	4	NONE	-	-	-	37.5	40
								E18	18	1	17.3	37.5	40
								E36	36	2	34.6	54.8	60
								E54	54	2	52	63.5	70

## ZJ180-300 - Standard Drive With Powered Convenience Outlet (Continued)

Size (Tons)	Volt	Compressors (each)			OD Fan Motors (each)	Supply Blower Motor	Pwr Conv Outlet	Electric Heat (Field Installed Accessory Only)				MCA <sup>1</sup> (Amps)	Max Fuse <sup>2</sup> / Breaker <sup>3</sup> Size (Amps)
		RLA	LRA	MCC	FLA	FLA	FLA	Model	kW	Stages	Amps		
300 (25)	208-3-60	22.4	149	35	2.2	26	10	NONE	-	-	-	140.9	150
								E18	13.5	1	37.5	140.9	150
								E36	27	2	74.9	140.9	150
								E54	40.6	2	112.7	185.9	200
								E72	54.1	2	150.2	195.2	200
	230-3-60	22.4	149	35	2.2	25	10	NONE	-	-	-	139.7	150
								E18	18	1	43.3	139.7	150
								E36	36	2	86.6	152	175
								E54	54	2	129.9	173.7	175
								E72	72	2	173.2	217	225
	460-3-60	10.6	75	16.5	1.1	12.5	5	NONE	-	-	-	67.4	70
								E18	18	1	21.7	67.4	70
								E36	36	2	43.3	76	80
								E54	54	2	65	86.8	90
								E72	72	2	86.6	108.5	110
	575-3-60	7.7	54	12	0.9	10	4	NONE	-	-	-	50.9	60
								E18	18	1	17.3	50.9	60
								E36	36	2	34.6	60.8	70
								E54	54	2	52	69.5	70
								E72	72	2	69.3	86.8	90

1. Minimum Circuit Ampacity.
2. Dual Element, Time Delay Type.
3. HACR type per NEC.

**ZJ180-300 - High Static Drive Without Powered Convenience Outlet**

Size (Tons)	Volt	Compressors (each)			OD Fan Motors (each)	Supply Blower Motor	Pwr Conv Outlet	Electric Heat (Field Installed Accessory Only)				MCA <sup>1</sup> (Amps)	Max Fuse <sup>2/</sup> Breaker <sup>3</sup> Size (Amps)
		RLA	LRA	MCC	FLA	FLA	FLA	Model	kW	Stages	Amps		
180 (15)	208-3-60	13.1	83.1	20.5	2.1	13.5	0	NONE	-	-	-	77.7	90
								E18	13.5	1	37.5	77.7	90
								E36	27	2	74.9	110.6	125
								E54	40.6	2	112.7	157.7	175
	230-3-60	13.1	83.1	20.5	2.1	13	0	NONE	-	-	-	77.1	90
								E18	18	1	43.3	77.1	90
								E36	36	2	86.6	124.5	125
								E54	54	2	129.9	146.2	175
	460-3-60	6.1	41	9.5	1.26	6.5	0	NONE	-	-	-	37.6	40
								E18	18	1	21.7	37.6	40
								E36	36	2	43.3	62.3	70
								E54	54	2	65	73.1	80
	575-3-60	4.4	33	6.8	0.66	5.2	0	NONE	-	-	-	26.7	30
								E18	18	1	17.3	28.2	30
								E36	36	2	34.6	49.8	50
								E54	54	2	52	58.5	70
210 (17.5)	208-3-60	14.5	98	22.6	2.1	20	0	NONE	-	-	-	91.4	110
								E18	13.5	1	37.5	91.4	110
								E36	27	2	74.9	118.7	125
								E54	40.6	2	112.7	165.9	175
	230-3-60	14.5	98	22.6	2.1	19.4	0	NONE	-	-	-	90.7	110
								E18	18	1	43.3	90.7	110
								E36	36	2	86.6	132.5	150
								E54	54	2	129.9	154.2	175
	460-3-60	6.3	55	9.9	1.26	9.7	0	NONE	-	-	-	42.4	50
								E18	18	1	21.7	42.4	50
								E36	36	2	43.3	66.3	70
								E54	54	2	65	77.1	90
	575-3-60	6	41	9.4	0.66	7.8	0	NONE	-	-	-	36.4	40
								E18	18	1	17.3	36.4	40
								E36	36	2	34.6	53.1	60
								E54	54	2	52	61.7	70
240 (20)	208-3-60	15.6	110	24.4	2.2	20	0	NONE	-	-	-	96.2	110
								E18	13.5	1	37.5	96.2	110
								E36	27	2	74.9	118.7	125
								E54	40.6	2	112.7	165.9	175
	230-3-60	15.6	110	24.4	2.2	19.4	0	NONE	-	-	-	95.5	110
								E18	18	1	43.3	95.5	110
								E36	36	2	86.6	132.5	150
								E54	54	2	129.9	154.2	175
	460-3-60	7.8	52	12.1	1.1	9.7	0	NONE	-	-	-	47.7	50
								E18	18	1	21.7	47.7	50
								E36	36	2	43.3	66.3	70
								E54	54	2	65	77.1	90
	575-3-60	5.8	38.9	9.1	0.9	7.8	0	NONE	-	-	-	36.6	40
								E18	18	1	17.3	36.6	40
								E36	36	2	34.6	53.1	60
								E54	54	2	52	61.7	70

## ZJ180-300 - High Static Drive Without Powered Convenience Outlet (Continued)

Size (Tons)	Volt	Compressors (each)			OD Fan Motors (each)	Supply Blower Motor	Pwr Conv Outlet	Electric Heat (Field Installed Accessory Only)				MCA <sup>1</sup> (Amps)	Max Fuse <sup>2</sup> / Breaker <sup>3</sup> Size (Amps)
		RLA	LRA	MCC	FLA	FLA	FLA	Model	kW	Stages	Amps		
300 (25)	208-3-60	22.4	149	35	2.2	37.2	0	NONE	-	-	-	144.9	175
								E18	13.5	1	37.5	144.9	175
								E36	27	2	74.9	144.9	175
								E54	40.6	2	112.7	187.4	200
								E72	54.1	2	150.2	196.7	225
	230-3-60	22.4	149	35	2.2	34.6	0	NONE	-	-	-	141.7	175
								E18	18	1	43.3	141.7	175
								E36	36	2	86.6	151.5	175
								E54	54	2	129.9	173.2	200
								E72	72	2	173.2	216.5	250
	460-3-60	10.6	75	16.5	1.1	17.3	0	NONE	-	-	-	68.4	80
								E18	18	1	21.7	68.4	80
								E36	36	2	43.3	75.8	80
								E54	54	2	65	86.6	100
								E72	72	2	86.6	108.2	125
	575-3-60	7.7	54	12	0.9	14.5	0	NONE	-	-	-	52.5	60
								E18	18	1	17.3	52.5	60
								E36	36	2	34.6	61.4	70
								E54	54	2	52	70.1	80
								E72	72	2	69.3	87.4	100

1. Minimum Circuit Ampacity.
2. Dual Element, Time Delay Type.
3. HACR type per NEC.

ZJ180-300 - High Static Drive With Powered Convenience Outlet

Size (Tons)	Volt	Compressors (each)			OD Fan Motors (each)	Supply Blower Motor	Pwr Conv Outlet	Electric Heat (Field Installed Accessory Only)				MCA <sup>1</sup> (Amps)	Max Fuse <sup>2/</sup> Breaker <sup>3</sup> Size (Amps)
		RLA	LRA	MCC	FLA	FLA	FLA	Model	kW	Stages	Amps		
180 (15)	208-3-60	13.1	83.1	20.5	2.1	13.5	10	NONE	-	-	-	87.7	100
								E18	13.5	1	37.5	87.7	100
								E36	27	2	74.9	123.1	125
								E54	40.6	2	112.7	170.2	175
	230-3-60	13.1	83.1	20.5	2.1	13	10	NONE	-	-	-	87.1	100
								E18	18	1	43.3	87.1	100
								E36	36	2	86.6	137	150
								E54	54	2	129.9	158.7	175
	460-3-60	6.1	41	9.5	1.26	6.5	5	NONE	-	-	-	42.6	45
								E18	18	1	21.7	42.6	45
								E36	36	2	43.3	68.5	70
								E54	54	2	65	79.3	90
	575-3-60	4.4	33	6.8	0.66	5.2	4	NONE	-	-	-	30.7	35
								E18	18	1	17.3	33.2	35
								E36	36	2	34.6	54.8	60
								E54	54	2	52	63.5	70
210 (17.5)	208-3-60	14.5	98	22.6	2.1	20	10	NONE	-	-	-	101.4	110
								E18	13.5	1	37.5	101.4	110
								E36	27	2	74.9	131.2	150
								E54	40.6	2	112.7	178.4	200
	230-3-60	14.5	98	22.6	2.1	19.4	10	NONE	-	-	-	100.7	110
								E18	18	1	43.3	100.7	110
								E36	36	2	86.6	145	150
								E54	54	2	129.9	166.7	175
	460-3-60	6.3	55	9.9	1.26	9.7	5	NONE	-	-	-	47.4	50
								E18	18	1	21.7	47.4	50
								E36	36	2	43.3	72.5	80
								E54	54	2	65	83.3	90
	575-3-60	6	41	9.4	0.66	7.8	4	NONE	-	-	-	40.4	45
								E18	18	1	17.3	40.4	45
								E36	36	2	34.6	58.1	60
								E54	54	2	52	66.7	70
240 (20)	208-3-60	15.6	110	24.4	2.2	20	10	NONE	-	-	-	106.2	125
								E18	13.5	1	37.5	106.2	125
								E36	27	2	74.9	131.2	150
								E54	40.6	2	112.7	178.4	200
	230-3-60	15.6	110	24.4	2.2	19.4	10	NONE	-	-	-	105.5	110
								E18	18	1	43.3	105.5	110
								E36	36	2	86.6	145	150
								E54	54	2	129.9	166.7	175
	460-3-60	7.8	52	12.1	1.1	9.7	5	NONE	-	-	-	52.7	60
								E18	18	1	21.7	52.7	60
								E36	36	2	43.3	72.5	80
								E54	54	2	65	83.3	90
	575-3-60	5.8	38.9	9.1	0.9	7.8	4	NONE	-	-	-	40.6	45
								E18	18	1	17.3	40.6	45
								E36	36	2	34.6	58.1	60
								E54	54	2	52	66.7	70

## ZJ180-300 - High Static Drive With Powered Convenience Outlet (Continued)

Size (Tons)	Volt	Compressors (each)			OD Fan Motors (each)	Supply Blower Motor	Pwr Conv Outlet	Electric Heat (Field Installed Accessory Only)				MCA <sup>1</sup> (Amps)	Max Fuse <sup>2</sup> / Breaker <sup>3</sup> Size (Amps)
		RLA	LRA	MCC	FLA	FLA	FLA	Model	kW	Stages	Amps		
300 (25)	208-3-60	22.4	149	35	2.2	37.2	10	NONE	-	-	-	154.9	175
								E18	13.5	1	37.5	154.9	175
								E36	27	2	74.9	154.9	175
								E54	40.6	2	112.7	199.9	200
	230-3-60	22.4	149	35	2.2	34.6	10	NONE	-	-	-	151.7	175
								E18	18	1	43.3	151.7	175
								E36	36	2	86.6	164	175
								E54	54	2	129.9	185.7	200
	460-3-60	10.6	75	16.5	1.1	17.3	5	NONE	-	-	-	73.4	90
								E18	18	1	21.7	73.4	90
								E36	36	2	43.3	82	90
								E54	54	2	65	92.8	100
	575-3-60	7.7	54	12	0.9	14.5	4	NONE	-	-	-	56.5	70
								E18	18	1	17.3	56.5	70
								E36	36	2	34.6	66.4	70
								E54	54	2	52	75.1	80
							E72	72	2	69.3	92.4	100	

1. Minimum Circuit Ampacity.
2. Dual Element, Time Delay Type.
3. HACR type per NEC.

**ZJ300 - Low Static Drive Without Powered Convenience Outlet**

Size (Tons)	Volt	Compressors (each)			OD Fan Motors (each)	Supply Blower Motor	Pwr Conv Outlet	Electric Heat (Field Installed Accessory Only)				MCA <sup>1</sup> (Amps)	Max Fuse <sup>2/</sup> Breaker <sup>3</sup> Size (Amps)
		RLA	LRA	MCC	FLA	FLA	FLA	Model	kW	Stages	Amps		
300 (25)	208-3-60	22.4	149	35	2.2	20	0	NONE	-	-	-	124	125
								E18	13.5	1	37.5	124	125
								E36	27	2	74.9	124	125
								E54	40.6	2	112.7	165.9	175
	230-3-60	22.4	149	35	2.2	19.4	0	NONE	-	-	-	123.4	125
								E18	18	1	43.3	123.4	125
								E36	36	2	86.6	132.5	150
								E54	54	2	129.9	154.2	175
	460-3-60	10.6	75	16.5	1.1	9.7	0	NONE	-	-	-	59.2	60
								E18	18	1	21.7	59.2	60
								E36	36	2	43.3	66.3	70
								E54	54	2	65	77.1	90
	575-3-60	7.7	54	12	0.9	7.8	0	NONE	-	-	-	44.2	50
								E18	18	1	17.3	44.2	50
								E36	36	2	34.6	53.1	60
								E54	54	2	52	61.7	70
							E72	72	2	69.3	79	90	

1. Minimum Circuit Ampacity.
2. Dual Element, Time Delay Type.
3. HACR type per NEC.

**ZJ300 - Low Static Drive With Powered Convenience Outlet**

Size (Tons)	Volt	Compressors (each)			OD Fan Motors (each)	Supply Blower Motor	Pwr Conv Outlet	Electric Heat (Field Installed Accessory Only)				MCA <sup>1</sup> (Amps)	Max Fuse <sup>2/</sup> Breaker <sup>3</sup> Size (Amps)
		RLA	LRA	MCC	FLA	FLA	FLA	Model	kW	Stages	Amps		
300 (25)	208-3-60	22.4	149	35	2.2	20	10	NONE	-	-	-	134	150
								E18	13.5	1	37.5	134	150
								E36	27	2	74.9	134	150
								E54	40.6	2	112.7	178.4	200
	230-3-60	22.4	149	35	2.2	19.4	10	NONE	-	-	-	133.4	150
								E18	18	1	43.3	133.4	150
								E36	36	2	86.6	145	150
								E54	54	2	129.9	166.7	175
	460-3-60	10.6	75	16.5	1.1	9.7	5	NONE	-	-	-	64.2	70
								E18	18	1	21.7	64.2	70
								E36	36	2	43.3	72.5	80
								E54	54	2	65	83.3	90
	575-3-60	7.7	54	12	0.9	7.8	4	NONE	-	-	-	48.2	50
								E18	18	1	17.3	48.2	50
								E36	36	2	34.6	58.1	60
								E54	54	2	52	66.7	70
							E72	72	2	69.3	84	90	

1. Minimum Circuit Ampacity.
2. Dual Element, Time Delay Type.
3. HACR type per NEC.



Table 9: ZJ180-300 Physical Data

Component	Models							
	ZJ180		ZJ210		ZJ240		ZJ300	
Nominal Tonnage	15		17.5		20		25	
<b>AHRI COOLING PERFORMANCE</b>								
Gross Capacity @ AHRI A point (Btu)	181400		208000		255000		290000	
AHRI net capacity (Btu)	172000		202000		240000		280000	
EER	12.2		12.1		11.0		10.5	
SEER	-		-		-		-	
IEER with Constant Volume	13.4		13		12		11.0	
IEER with Intellispeed	14.0 <sup>1</sup> /13.8 <sup>2</sup>		13.2 <sup>1</sup> /13.0 <sup>2</sup>		13.2 <sup>1</sup> /13.0 <sup>2</sup>		12.3 <sup>1</sup> /12.1 <sup>2</sup>	
IEER with VAV	13.4		13		12		11.0	
CFM	4500		5800		7000		7000	
System power (KW)	14.10		16.70		21.82		26.67	
Refrigerant type	R-410a		R-410a		R-410a		R-410a	
Refrigerant charge (lb-oz)								
System 1	12-0		14-0		12-0		12-4	
System 2	11-12		12-8		13-0		12-8	
System 3	12-4		12-8		12-0		12-8	
System 4	13-8		12-8		12-0		12-8	
<b>AHRI HEATING PERFORMANCE</b>								
Heating model	N30	N40	N30	N40	N30	N40	N30	N40
Heat input (K Btu)	300	400	300	400	300	400	300	400
Heat output (K Btu)	240	320	240	320	240	320	240	320
AFUE %	-	-	-	-	-	-	-	-
Steady state efficiency (%)	80	80	80	80	80	80	80	80
No. burners	6	8	6	8	6	8	6	8
No. stages	2	2	2	2	2	2	2	2
Temperature Rise Range (°F)	20-50	30-60	20-50	30-60	20-50	30-60	20-50	30-60
Gas Limit Setting (°F)	195	195	195	195	195	195	195	195
Gas piping connection (in.)	1	1	1	1	1	1	1	1
<b>DIMENSIONS (inches)</b>								
Length	180-19/32							
Width	92							
Height	52-5/8							
<b>OPERATING WT. (lbs.)</b>	2609		2665		2697		2783	
<b>COMPRESSORS</b>								
Type	Scroll		Scroll		Scroll		Scroll	
Quantity	4		4		4		4	
Unit Capacity Steps (%)	25 / 50 / 75 / 100		25 / 50 / 75 / 100		25 / 50 / 75 / 100		25 / 50 / 75 / 100	
<b>CONDENSER COIL DATA</b>								
Face area (Sq. Ft.)	63.8		63.8		63.8		63.8	
Rows	2		2		2		2	
Fins per inch	20		20		20		20	
Tube diameter (in.)	3/8		3/8		3/8		3/8	
Circuitry Type	Split-face		Split-face		Split-face		Split-face	
<b>EVAPORATOR COIL DATA</b>								
Face area (Sq. Ft.)	25		25		25		25	
Rows	4		4		4		4	
Fins per inch	13.5		13.5		13.5		13.5	
Tube diameter	3/8		3/8		3/8		3/8	
Circuitry Type	Split-face		Split-face		Split-face		Split-face	
Refrigerant control	TXV		TXV		TXV		TXV	

**Table 9: ZJ180-300 Physical Data (Continued)**

Component	Models								
	ZJ180		ZJ210		ZJ240		ZJ300		
Nominal Tonnage	15		17.5		20		25		
<b>CONDENSER FAN DATA</b>									
Quantity	4		4		4		4		
Fan diameter (Inch)	24		24		30		30		
Type	Prop		Prop		Prop		Prop		
Drive type	Direct		Direct		Direct		Direct		
No. speeds	1		1		1		1		
Number of motors	2		4		4		2		
Motor HP each	1/3		1/3		1/3		1/3		
RPM	850		850		870		870		
Total CFM	16000		16000		20000		20000		
<b>BELT DRIVE EVAP FAN DATA</b>									
Quantity	1		1		1		1		
Fan Size (Inch)	15 X 15		18 X 15		18 X 15		18 X 15		
Type	Centrifugal		Centrifugal		Centrifugal		Centrifugal		
Motor Sheave	1VP65	1VP65	1VP60	1VP60	1VP60	1VP60	1VP60	1VP75X	1VP75X
Blower Sheave	BK110	BK090	BK110	BK090	BK110	BK090	1B5V94	1B5V110	1B5V94
Belt	BX83	BX81	BX78	BX75	BX78	BX75	BX78	5VX840	5VX860
Motor HP each	5	5	5	7.5	5	7.5	7.5	10	15
RPM	1725	1725	1725	1725	1725	1725	1725	1725	1725
Frame size	184T	184T	184T	213T	184T	213T	213T	215T	254T
<b>FILTERS</b>									
Quantity - Size	12 - (12 x 24 x 2) <sup>3,4</sup>		12 - (12 x 24 x 2) <sup>3,4</sup>		12 - (12 x 24 x 2) <sup>3,4</sup>		12 - (12 x 24 x 2) <sup>3,4</sup>		
	2 - (20 x 24 x 4), 4 - (24 x 24 x 4) <sup>5</sup>		2 - (20 x 24 x 4), 4 - (24 x 24 x 4) <sup>5</sup>		2 - (20 x 24 x 4), 4 - (24 x 24 x 4) <sup>5</sup>		2 - (20 x 24 x 4), 4 - (24 x 24 x 4) <sup>5</sup>		

1. Cooling Only Unit
2. Cooling Unit with Gas or Electric Heat
3. 2 In. Throwaway, Standard, MERV (Minimum Efficiency Reporting Value) 3.
4. 2 In. Pleated, Optional, MERV 8.
5. 4 In. Pleated, Optional, MERV 13.

## Field Installed Electric Heat Accessories

These field-installed heater accessories can be wired for single point power supply.

These CSA approved heater accessories shall be located within the central compartment of the unit with the heater elements extending into the supply air chamber.

Fuses are supplied, where required. Some kW sizes require fuses and others do not. Refer to Table 10 for minimum CFM limitations and to Table 8 for electrical data.

**Table 10: Electric Heat Minimum Supply Air**

Size (Tons)	Voltage	Minimum Supply Air (CFM)			
		Heater kW			
		18	36	54	72
180 (15)	208/230-3-60	4500	4500	5000	5000
	460-3-60	4500	4500	5000	4500
	600-3-60	4500	4500	4500	4500
210 (17.5)	208/230-3-60	6000	6000	6000	6000
	460-3-60	6000	6000	6000	6000
	600-3-60	6000	6000	6000	6000
240 (20)	208/230-3-60	6000	6000	6000	6000
	460-3-60	6000	6000	6000	6000
	600-3-60	6000	6000	6000	6000
300 (25)	208/230-3-60	7500	7500	7500	7500
	460-3-60	7500	7500	7500	7500
	600-3-60	7500	7500	7500	7500

## Optional Gas Heat

These gas-fired heaters have aluminized-steel or optional stainless steel, tubular heat exchangers with spark ignition with proven pilot.

utility requirements. Refer to the Pipe Sizing Table 12. The heating value of the gas may differ with locality. The value should be checked with the local gas utility.

**Table 11: Gas Application Data**

Unit		Input (MBH)	Output (MBH)	Temp Rise (°F) <sup>1</sup>
Size	Opt.			
180	N30	300	240	20-50
	N40	400	320	35-65
210	N30	300	240	20-50
	N40	400	320	35-65
240	N30	300	240	20-50
	N40	400	320	35-65
300	N30	300	240	20-50
	N40	400	320	35-65

1. On VAV units, individual VAV boxes must be full open in heating mode to insure airflow falls within temperature rise range.

## Gas Piping

Proper sizing of gas piping depends on the cubic feet per hour of gas flow required, specific gravity of the gas and the length of run. "National Fuel Gas Code" Z223.1 (in U.S.A.) or the current Gas Installation Codes CSA-B149.1 (in Canada) should be followed in all cases unless superseded by local codes or gas

**NOTE:** There may be a local gas utility requirement specifying a minimum diameter for gas piping. All units require a one-inch pipe connection at the entrance fitting.

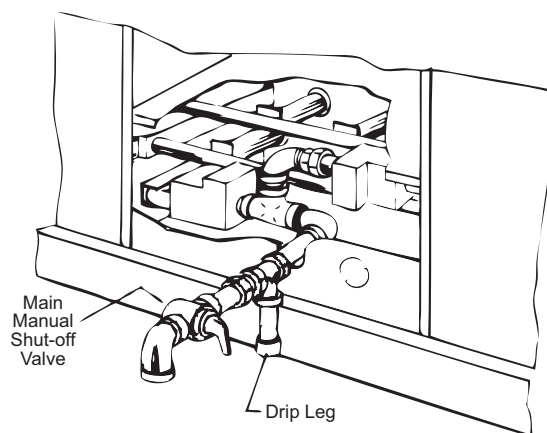

**Figure 13: External Supply Connection External Shut-Off**

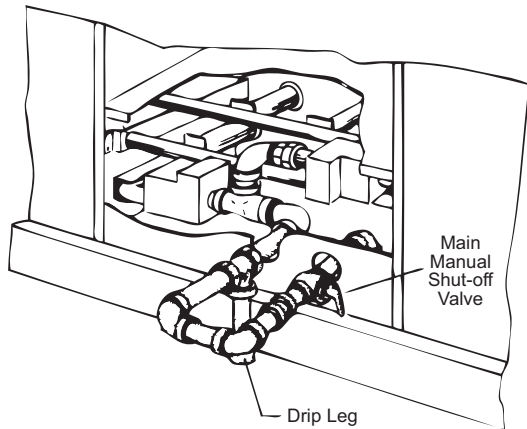

Figure 14: Bottom Supply Connection External Shut-Off

Table 12: Gas Pipe Sizing - Capacity of Pipe

Length of Pipe (ft.)	Nominal Iron Pipe Size	
	1 in.	1-1/4 in.
10	520	1050
20	350	730
30	285	590
40	245	500
50	215	440
60	195	400
70	180	370
80	170	350
90	160	320
100	150	305

**NOTE:** Maximum capacity of pipe in cubic feet of gas per hour based upon a pressure drop of 0.3 inch W.C. and 0.6 specific gravity gas.

Table 13: Gas Heat Minimum Supply Air

Size (Tons)	Heat Size	Supply Air (CFM)			
		Cooling		Heating	
		Min	Max	Min	Max
180 (15)	N30	4500	7000	4500	7000
	N40	4500	7000	4500	7000
210 (17.5)	N30	6000	8750	6000	8750
	N40	6000	8750	6000	8750
240 (20)	N30	6000	9400	6000	9400
	N40	6000	9400	6000	9400
300 (25)	N30	7500	12500	7500	12500
	N40	7500	12500	7500	12500

**Gas Connection**

The gas supply line can be routed within the space and roof curb, exiting through the unit's basepan. Refer to Figure 5 for the gas piping inlet location. Typical supply piping arrangements are shown in Figures 13 and 14. All pipe nipples, fittings, and the gas cock are field supplied.

Gas piping recommendations:

1. A drip leg and a ground joint union must be installed in the gas piping.

2. Where required by local codes, a manual shut-off valve must be installed outside of the unit.
3. Use wrought iron or steel pipe for all gas lines. Pipe dope should be applied sparingly to male threads only.

**▲ WARNING**

Natural gas may contain some propane. Propane is an excellent solvent and will quickly dissolve white lead and most standard commercial compounds. A special pipe dope must be used when assembling wrought iron or steel pipe. Shellac based compounds such as Gaskolac or Stalastic, and compounds such as Rectorseal #5, Clydes's or John Crane may be used.

4. All piping should be cleaned of dirt and scale by hammering on the outside of the pipe and blowing out loose particles. Before initial start-up, be sure that all gas lines external to the unit have been purged of air.
5. The gas supply should be a separate line and installed in accordance with all safety codes as prescribed under "Limitations".
6. A 1/8-inch NPT plugged tapping, accessible for test gage connection, must be installed immediately upstream of the gas supply connection to the unit.
7. After the gas connections have been completed, open the main shut-off valve admitting *normal gas pressure* to the mains. *Check all joints for leaks with soap solution or other material suitable for the purpose. NEVER USE A FLAME.*

**▲ WARNING**

**FIRE OR EXPLOSION HAZARD**

Failure to follow the safety warning exactly could result in serious injury, death or property damage.

Never test for gas leaks with an open flame. use a commercially available soap solution made specifically for the detection of leaks to check all connections. A fire or explosion may result causing property damage, personal injury or loss of life.

**▲ CAUTION**

The furnace and its individual shut-off valve must be disconnected from the gas supply piping system during any pressure testing at pressures in excess of 1/2 PSIG. Pressures greater than 1/2 PSIG will cause gas valve damage resulting in a hazardous condition. If it is subjected to a pressure greater than 1/2 PSIG, the gas valve must be replaced.

The furnace must be isolated from the gas supply piping system by closing its individual manual shut-off valve during any pressure testing of the gas supply piping system at test pressures equal to or less than 1/2 PSIG.

**WARNING**

Threaded joints should be coated with a sealing compound that is resistant to the action of liquefied petroleum gases. **Do not use Teflon tape.**

**Lp Units, Tanks And Piping**

All gas heat units are shipped from the factory equipped for natural gas use only. The unit may be converted in the field for use with LP gas with accessory kit model number 1NP0418.

All LP gas equipment must conform to the safety standards of the National Fire Protection Association.

For satisfactory operation, LP gas pressure must be 10.0 inch W.C. at the unit under full load. Maintaining proper gas pressure depends on three main factors:

1. The vaporization rate which depends on the temperature of the liquid and the "wetted surface" area of the container(s).
2. The proper pressure regulation. (Two-stage regulation is recommended).
3. The pressure drop in the lines between regulators and between the second stage regulator and the appliance. Pipe size required will depend on the length of the pipe run and the total load of all appliances.

Complete information regarding tank sizing for vaporization, recommended regulator settings, and pipe sizing is available from most regulator manufacturers and LP gas suppliers.

**WARNING**

LP gas is an excellent solvent and will quickly dissolve white lead and most standard commercial compounds. A special pipe dope must be used when assembling wrought iron or steel pipe for LP. Shellac base compounds such as Gaskolac or Stalastic, and compounds such as Rectorseal #5, Clyde's, or John Crane may be used.

Check all connections for leaks when piping is completed using a soap solution. **NEVER USE A FLAME.**

**WARNING****FIRE OR EXPLOSION HAZARD**

Failure to follow the safety warning exactly could result in serious injury, death or property damage.

Never test for gas leaks with an open flame. Use a commercially available soap solution made specifically for the detection of leaks to check all connections. A fire or explosion may result causing property damage, personal injury or loss of life.

**Vent And Combustion Air**

Two vent hoods and a combustion air hood (with screens) are shipped attached to the blower housing in the blower compartment. For units with factory installed VFD option, the hoods and accompanying hardware are shipped inside the gas heat section. These hoods must be installed to assure proper unit function. All hoods must be fastened to the outside of the gas heat access panel with the screws provided in the bag also attached to the blower housing.

The screen for the combustion air intake hood is secured to the inside of the access panel opening with four fasteners and the screws used for mounting the hood to the panel. The top flange of this hood slips in under the top of the access panel opening when installing. Refer to Vent and Combustion Air Hood Figure 15.

Each vent hood is installed by inserting the top flange of the hood into the slotted opening in the access panel and securing in place.

The products of combustion are discharged horizontally through these two screened, hooded vent openings on the upper gas heat access panel.

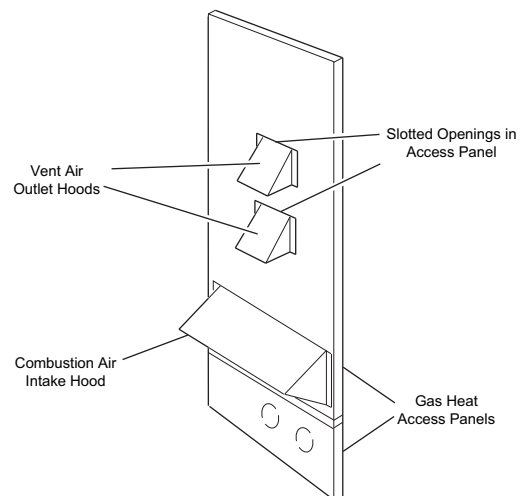

**Figure 15: Vent and Combustion Air Hood**

**Options/Accessories****Electric Heat**

Electric heaters are available as a field-installed accessory. These heaters mount in the heat compartment with the heating elements extending into the supply air chamber. All electric heaters are fused and intended for use with single point power supply.

**Economizer/Motorized Outdoor Damper Rain Hood**

The instruction for the optional economizer/motorized damper rain hood can be found in the rain hood kit. Use these instructions when field assembling an economizer rain hood onto a unit. The outdoor and return air dampers, the damper actuator, the damper linkage, the outdoor and return air divider

baffles, and all the control sensors are factory mounted as part of the "Factory installed" economizer option.

### Power Exhaust/Barometric Relief Damper and Rain Hood

The instructions for the power exhaust/barometric relief damper and rain hood can be found in the rain hood kit. The exhaust fan, all supporting brackets, angles, and the wiring are factory installed as part of the power exhaust option.

### Economizer Sequences

Several functions can drive the economizer, including: minimum position, free cooling, economizer loading, and minimum outdoor air supply.

#### *Economizer Minimum Position*

The economizer minimum position is set during occupied mode when outside air is not suitable for free cooling. The position of the damper is set proportionally between the "Economizer Minimum Position and the Economizer Minimum Position Low Speed Fan" set points, in relationship to the VFD output percentage. On a constant volume single speed supply fan system both set-points should be set to the same value.

#### *Free Cooling*

Four types of free cooling options are available: dry bulb changeover, single enthalpy, dual enthalpy changeover, and Auto.

#### **Dry Bulb Changeover**

For dry bulb economizer operation, the outside air is suitable for free cooling if the outside air temperature is 1°F below the Economizer OAT Enable Setpoint **and** 1°F below the Return Air Temperature.

Free cooling is no longer available if the outside air temperature rises above **either** the Economizer OAT Enable setpoint **or** the return air temperature.

#### **Single Enthalpy Changeover**

For single enthalpy economizer operation, the outside air is suitable for free cooling if the outside air enthalpy is at least 1 BTU/lb below the Economizer Outside Air Enthalpy Setpoint **and** the outside air temperature is no greater than the RAT plus 9°F.

If the outside air temperature rises above the RAT plus 10°F, free cooling is no longer available. The outside air temperature must drop to no greater than RAT plus 9°F to enter free cooling again.

Free cooling is no longer available if the outside air enthalpy rises above the Economizer Outside Air Enthalpy Setpoint.

#### **Dual Enthalpy Changeover**

For dual enthalpy economizer operation, the outside air enthalpy must be lower than the return air enthalpy by 1 btu/lb

AND the outside air temperature is no greater than the RAT plus 9°F.

### Auto

The control determines the type of free cooling changeover based on which sensors are present and reliable. Conditions include:

- Return and outside air dry bulb = dry bulb changeover
- Return and outside air dry bulb and outside air humidity = single enthalpy
- Return and outside air dry bulb and return and outside air humidity = dual enthalpy
- If either the return or outside air dry bulb sensors are unreliable, free cooling is not available

### Free Cooling Operation

When the control determines that the outside air is suitable, the first stage of cooling will always be free cooling.

#### *Thermostat*

In free cooling, with a thermostat input to Y1, the dampers modulate to control the supply air temperature to the Economizer Setpoint +/- 1°F (default 55°F).

If the thermostat provides an input to Y2 **and** the parameter Compressors Off in Free Cooling is turned OFF a compressor output energizes. The economizer dampers continue to modulate to control the supply air temperature to the Economizer Setpoint.

If the supply air temperature cannot be maintained within 5°F of the economizer setpoint, the first stage compressor (C1) will be turned on. Second stage compressor (C2) will be added as needed to keep the supply air temperature within the 5°F of the economizer setpoint.

#### *Sensor*

In free cooling, with a demand from the zone/return sensor for the first stage of cooling, the dampers modulate to control the supply air temperature to the Economizer Setpoint +/- 1°F.

If the economizer output is at 100% **and** the SAT is greater than the Economizer setpoint + 1°F, the control starts a 12-minute timer to energize a compressor output.

If at any time the economizer output drops below 100% the timer stops and resets when the economizer output returns to 100%.

Once a compressor output is turned ON, the economizer dampers continue to modulate to control the supply air temperature to the Economizer Setpoint.

At no time will a compressor output be turned ON if the economizer output is less than 100%, even if the differential between zone (or return) temperature and the current cooling setpoint is great enough to demand more than one stage of cooling.

If the economizer output goes to minimum position **and** the SAT is less than Economizer Setpoint -1°F, the control starts a 12-minute timer to de-energize a compressor output.

If at any time the economizer output goes above the minimum position the timer stops and resets when the economizer output returns to minimum position.

If the demand for cooling from the space/return is satisfied, the economizer output will modulate to minimum position and the compressor outputs will be de-energized as long as their minimum run timers have expired.

## Power Exhaust

### Setpoints

- |                                      |            |
|--------------------------------------|------------|
| a. Economizer Enable                 | ON         |
| b. Power Exhaust Enable              | ON         |
| c. Modulating Power Exhaust          | OFF        |
| d. Exhaust VFD Installed             | OFF        |
| e. Building Pressure Sensor Enabled  | OFF        |
| f. Econo Damper Position For Exh Fan | ON Percent |

- g. Econo Damper Position For Exh Fan OFF Percent

### Inputs

No inputs are present for non-modulating power exhaust.

### Outputs

- 2-10 VDC from ECON on Economizer Expansion module
- 24 VAC from EX-FAN to energize exhaust fan on Economizer Expansion module

### Operation

Operation details include:

- Compares economizer output to the Economizer Damper Position For Exhaust Fan On and OFF.
- Energizes exhaust fan when economizer output is above Economizer Damper Position For Exhaust Fan On.
- De-energizes exhaust fan when economizer output is below the Economizer Damper Position for Exhaust Fan OFF

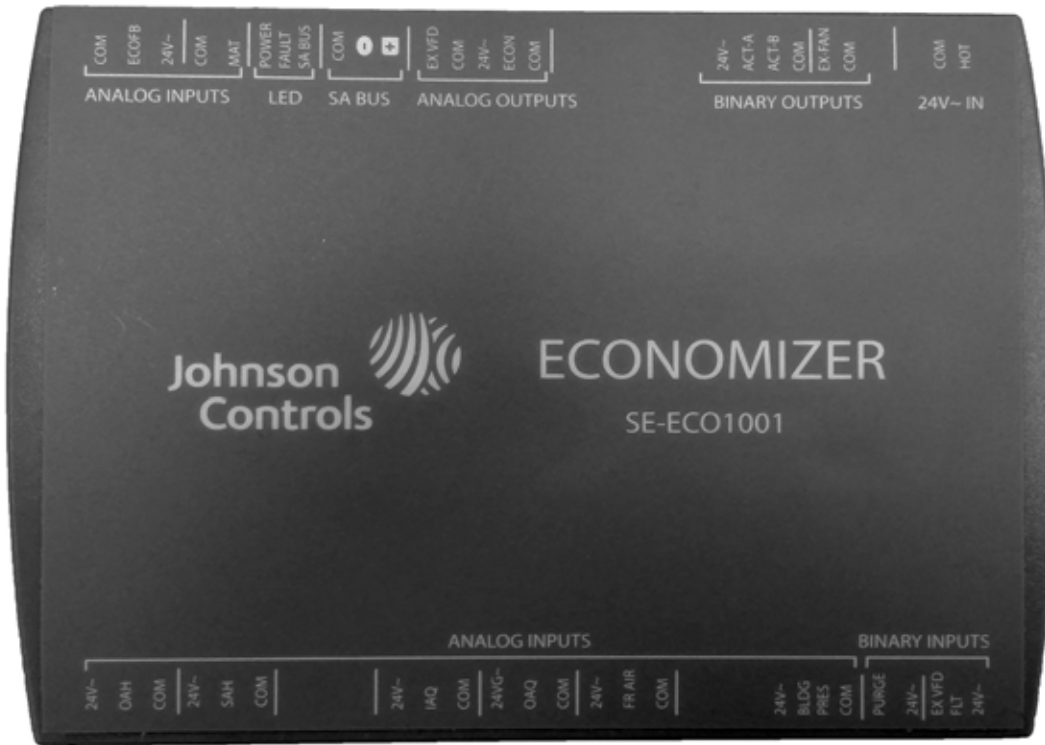

Figure 16: SE-ECO1001-0 Economizer Controller

Table 14: Simplicity SE Economizer Board Details

Board Label	Cover Label	Description	Function & Comments
<b>Directional orientation: viewed with the center text of the cover label upright</b>			
<b>ANALOG INPUTS Terminal at left on upper edge of economizer board</b>			
<b>C</b>	COM	24 VAC common/0-10 VDC negative for economizer actuator position feedback	Connects through circuit trace to 24V~ IN pin COM
<b>IN2</b>	ECOFB	0-10 VDC positive input from Economizer actuator position Feedback	EconDampPos parameter reports input status (0-100%). Used to meet Cali. Title 24 requirements for economizer actuator position feedback
<b>R</b>	24V~	24 VAC hot supplied for economizer actuator position feedback	Connects through circuit trace to 24V~ IN pin HOT
<b>C</b>	COM	Mixed Air Temperature sensor input from 10KΩ @ 77°F, Type III negative temperature coefficient thermistor	MAT parameter reports input status (°F/°C), 3.65 VDC reading MAT (+) to COM (-) with open circuit. Read-only use in current control revision.
<b>IN1</b>	MAT		
<b>LEDs at left on upper edge of economizer board</b>			
<b>POWER</b>	POWER	Green UCB power indicator	Lit indicates 24 VAC is present at 24V~ IN COM and HOT pins
<b>FAULT</b>	FAULT	Red networking error and firmware error indicator	1/10th second on/off flashing indicates a networking error (polarity, addressing, etc.) or a firmware error (likely correctable with re-loading from USB flash drive)
<b>SA BUS</b>	SA BUS	Green UCB SA bus communication transmission indicator	Lit/flickering indicates UCB-to-economizer board SA bus communication is currently active, off indicates the economizer board is awaiting SA bus communication
<b>SA BUS Pin connections at left on upper edge of economizer board</b>			
<b>C</b>	COM	Common for SA BUS power and communication circuits	EconCtrlr parameter reports UCB-to-economizer board SA bus communication status. Negative of the SA BUS communication circuit to the UCB. Through the unit wiring harness, may continue on to the 4-stage board and/or fault detection & diagnostics board



Table 14: Simplicity SE Economizer Board Details (Continued)

Board Label	Cover Label	Description	Function & Comments
-	-	Communication for SA BUS devices	EconCtrlr parameter reports UCB-to-economizer board SA BUS communication status. Positive of the VDC (typically, a fluctuating 1.5 to 3.5 volts reading to C; at least 0.25 volts lower than +) SA BUS communication circuit to the UCB. Through the unit wiring harness, may continue on to the 4-stage board and/or fault detection & diagnostics board
+	+	Communication for SA BUS devices	EconCtrlr parameter reports UCB-to-economizer board SA BUS communication status. Positive of the VDC (typically, a fluctuating 1.5 to 3.5 volts reading to C; at least 0.25 volts higher than -) SA BUS communication circuit to the UCB. Through the unit wiring harness, may continue on to the 4-stage board and/or fault detection & diagnostics board
<b>ANALOG OUTPUTS Pin at center on upper edge of economizer board</b>			
J4	EX VFD	2-10 VDC positive output for the modulating power Exhaust fan Variable Frequency Drive/ discharge damper modulating power exhaust actuator	ExFanVFD parameter reports output status (0-100%) when ExFType selection is Variable Frequency Fan; EAD-O parameter reports output status (0-100%) when ExFType selection is Modulating Damper. Used to ramp the power exhaust fan VFD/ position the discharge damper actuator.
	COM	24 VAC common/0-10 VDC negative for the power exhaust variable frequency drive/ discharge damper modulating power exhaust actuator	Connects through circuit trace to 24V~ IN pin COM
	24V~	24 VAC hot supplied for the discharge damper modulating power exhaust actuator and economizer actuator	Connects through circuit trace to 24V~ IN pin HOT
	ECON	2-10 VDC output for the Economizer actuator	Econ parameter reports output status (0-100%). Used to position the economizer actuator for minimum position, free cooling, demand ventilation, cooling economizer loading and purge functions
	COM	24 VAC common/0-10 VDC negative for economizer actuator	Connects through circuit trace to 24V~ IN pin COM
<b>BINARY OUTPUTS Pin at right on upper edge of economizer board</b>			
J3	24V~	24 VAC hot supplied for an incremental (floating control) economizer actuator	Connects through circuit trace to 24V~ IN pin HOT
	ACT-A	24 VAC hot outputs to position an incremental (floating control) economizer actuator	Unused in current control revision
	ACT-B	24 VAC return	Unused in current control revision
	COM	24 VAC common for an incremental (floating control) economizer actuator	Connects through circuit trace to 24V~ IN pin COM
	EX-FAN	24 VAC hot output to energize power exhaust fan contactor coil/VFD enable relay coil	ExFan parameter reports output status (Off-On) when ExFType selection is Non-Modulating, Modulating Damper or Variable Frequency Fan. Used to turn on/enable the power exhaust fan motor.
	COM	24 VAC common/0-10 VDC negative for economizer actuator	Connects through circuit trace to 24V~ IN pin COM
<b>24V~ IN Pin connections at right on upper edge of economizer board</b>			
C	COM	24 VAC transformer Common referenced to cabinet ground	24 VAC common connection to power the economizer board. Connects through circuit traces to C/COM terminals and pins distributed on the economizer board.

**Table 14: Simplicity SE Economizer Board Details (Continued)**

Board Label	Cover Label	Description	Function & Comments
R	HOT	24 VAC transformer HOT	24 VAC hot connection to power the economizer board. Connects through circuit traces to R/24V~ terminals and pins distributed on the economizer board.
<b>ANALOG INPUTS Terminal on lower edge of economizer board</b>			
R	24V~	24 VAC hot supplied for the outdoor air humidity sensor	Connects through circuit trace to 24V~ IN pin HOT
IN3	OAH	0-10 VDC positive input from the Outdoor Air Humidity sensor	OAH parameter reports input status (0-100%H). Used in outdoor air enthalpy calculation for dual enthalpy economizer free cooling changeover.
C	COM	24 VAC common/0-10 VDC negative for the outdoor air humidity sensor	Connects through circuit trace to 24V~ IN pin COM
R	24V~	24 VAC hot supplied for the supply air humidity sensor	Connects through circuit trace to 24V~ IN pin HOT
IN4	SAH	0-10 VDC positive input from the Supply Air Humidity sensor	SAH parameter reports input status (0-100%H). Unused in current control revision.
C	COM	24 VAC common/0-10 VDC negative for the supply air humidity sensor	Connects through circuit trace to 24V~ IN pin COM
R	24V~	24 VAC hot supplied for the indoor air quality sensor	Connects through circuit trace to 24V~ IN pin HOT
IN5	IAQ	0-10 VDC positive input from the Indoor Air Quality sensor	IAQRange parameter sets the CO2 parts per million measured by the indoor air quality sensor when it outputs 10 VDC; IAQ parameter reports input status (0-5000ppm). Used for demand ventilation functions if the NetIAQ parameter indicates ?Unrel.
C	COM	24 VAC common/0-10 VDC negative for the indoor air quality sensor	Connects through circuit trace to 24V~ IN pin COM
R	24V~	24 VAC hot supplied for the outdoor air quality sensor	Connects through circuit trace to 24V~ IN pin HOT
IN6	OAQ	0-10 VDC positive input from the Outdoor Air Quality sensor	OAQRange parameter sets the CO2 parts per million measured by the outdoor air quality sensor when it outputs 10 VDC; OAQ parameter reports input status (0-5000ppm). Used for demand ventilation function when DVent-Mode selection is Diff between IAQ and OAQ and the NetOAQ parameter indicates ?Unrel.
C	COM	24 VAC common/0-10 VDC negative for the outdoor air quality sensor	Connects through circuit trace to 24V~ IN pin COM
R	24V~	24 VAC hot supplied for the air monitoring station sensor	Connects through circuit trace to 24V~ IN pin HOT
IN7	FR AIR	0-10 VDC positive input from the air monitoring station sensor	MOA-Range parameter sets the cubic feet per minute/liters per second measured by the air monitoring station sensor when it outputs 10 VDC; Fr Air parameter reports input status (0-5000CFM/23595lps). Used for economizer minimum position reset in speed-controlled indoor blower applications.
C	COM	24 VAC common/0-10 VDC negative for the air monitoring station sensor	Connects through circuit trace to 24V~ IN pin COM
R	24V~	24 VAC hot supplied for the building pressure sensor	Connects through circuit trace to 24V~ IN pin HOT
IN8	BLDG PRES	0-5 VDC positive input from the Building Pressure sensor	BldgPres parameter reports input status (-.250-.250"/w/-.062-.062kPa). Used for modulating power exhaust functions when ExFType selection is Modulating Damper or Variable Frequency Fan.

**Table 14: Simplicity SE Economizer Board Details (Continued)**

Board Label	Cover Label	Description	Function & Comments
C	COM	24 VAC common/0-5 VDC negative for the building pressure sensor	Connects through circuit trace to 24V~ IN pin COM
<b>BINARY INPUTS at right on lower edge of economizer board</b>			
IN9	PURGE	24 VAC hot input from the PURGE dry contact	Purge parameter reports input status (False with 0 VAC input-True with 24 VAC input). When Purge status is True, heating and cooling operation is prevented, the indoor blower and power exhaust fan operate, the economizer actuator is positioned to 100%.
	24V~	24 VAC hot supplied for the purge dry contact	Connects through circuit trace to 24V~ IN pin HOT
IN10	EX VFD FLT	24 VAC hot input from the power Exhaust Variable Frequency Drive Fault contact	ExFanVFDFIt parameter reports input status (Normal with 0 VAC input-Alarm with 24 VAC input) when ExFType selection is Variable Frequency Fan. When ExFanVFDFIt status is Alarm, EX-FAN fan output is prevented.
	24V~	24 VAC hot supplied for the power exhaust variable frequency drive fault contact	Connects through circuit trace to 24V~ IN pin HOT

### Power Exhaust Damper Set Point

With power exhaust option, each building pressurization requirement will be different. The point at which the power exhaust comes on is determined by the economizer damper position (Percent Open). The Exhaust Air Adjustment Screw should be set at the Percent Open of the economizer damper at which the power exhaust is needed. It can be set from 0 to 100% damper open.

### Indoor Air Quality - IAQ

Indoor Air Quality (indoor sensor input): The Indoor Air Quality sensor is connected to the economizer board through the IAQ analog input terminal and the associated COM and 24V~ inputs on the economizer board. Terminal IAQ accepts a 0 to +10 Vdc signal with respect to the (IAQ) terminal. When the signal is below its set point, the actuator is allowed to modulate normally in accordance with the enthalpy and mixed air sensor inputs. When the IAQ signal exceeds its set point setting, and there is no call for free cooling, the actuator is proportionately modulated from the 0 to 10 Vdc signal, with 0 Vdc corresponding to full closed and 10 Vdc corresponding to full open. When there is no call for free cooling, the damper position is limited by the IAQ Max damper position setting. When the signal exceeds its set point (Demand Control Ventilation Set Point) setting and there is a call for free cooling, the actuator modulates from the minimum position to the full open position based on the highest call from either the mixed air sensor input or the IAQ voltage input.

- Optional CO2 Space Sensor Kit Part #2AQ04700524
- Optional CO2 Sensor Kit Part #2AQ04700624

### Optional BAS-Ready Economizer Power Exhaust Damper Set Point Adjustment

Remove the economizer access panel from the unit. Loosen, but do not remove the two panel latches. Locate the

economizer actuator, where the following adjustment can be made.

With power exhaust option, each building pressurization requirement will be different. The point at which the power exhaust comes on is determined by the economizer's outdoor damper position. The actuator's auxiliary switch adjustment screw should be set at the damper position at which the power exhaust is needed. The adjustment screw can be set between 25 to 85 degrees open.

Replace the economizer access panel.

### Optional Variable Air Volume (VAV)

A variable air volume (VAV) option using a variable frequency drive (VFD) is available for applications requiring a constant supply duct static pressure. A differential pressure transducer is used to monitor supply duct static pressure and return a speed reference signal to the VFD to control the output of the indoor blower motor.

### Duct Static Pressure Transducer

A 0-5" WC pressure transducer, located in the control box compartment, is used to sense static (gauge) pressure in the supply air duct and convert this pressure measurement to a proportional 0-5 VDC electrical output.

Pressure-transmitting plastic tubing (1/4" diameter) must be field supplied and installed from the transducer to both the ductwork and to the atmosphere. Connect the tubing from the 'HIGH' pressure tap of the transducer to a static pressure tap (field supplied) in the supply duct located at a point where constant pressure is expected. To prevent an unstable signal due to air turbulence, there should be no obstructions, turns or VAV terminal boxes up- or down-stream of the sensing tube location for at least a distance of 6-10 times the duct diameter. Tubing must also be run between the 'LOW' pressure tap of the transducer and atmospheric pressure (outside of the unit).

**▲ CAUTION**

Do not run plastic tubing in the supply or return air ducts as air movement could cause erroneous pressure measurements. If the tubing penetrates through the bottom of the unit be sure openings are sealed to prevent air and water leakage.

**Factory-installed VFD**

The factory-installed VFD is mounted in the Blower Access Compartment above the blower assembly. The drive comes wired from the factory to include both 3-phase power and control connections (run permit signal, speed reference signal & fault signal).

All required drive parameters are pre-programmed at the factory, except in the case of 208-volt applications, in which the parameter that defines motor nameplate voltage must be changed to a value of 208.00 and the parameter that defines motor-rated current must be changed to the appropriate value appearing on the motor's nameplate. Refer to the enclosed drive material or access the UPGnet Commercial Product Catalog website for instructions on changing parameter settings.

**Manual Bypass**

An optional, factory-installed manual bypass switch available with factory-installed VFD can be found in the Blower Motor Access compartment and has the following three positions:

- **DRIVE** - routes power through the VFD for modulating control of the indoor blower motor.
- **LINE** (or BYPASS) - routes power directly to the motor which provides full-speed motor operation and complete electrical isolation of the drive.
- **TEST** - routes power to the VFD but not to the motor to allow for drive programming and/or diagnostics.

If a drive failure occurs, the unit does not automatically switch to bypass mode. The LINE/DRIVE/TEST switch must be manually switched to the LINE (BYPASS) position. If there is a call for the fan, the indoor blower motor will run at full-speed while in the bypass mode.

**▲ CAUTION**

If the unit is operated with the manual bypass switch in the LINE (BYPASS) position and there are VAV boxes present in the duct system, then boxes must be driven to the full-open position using a customer-supplied power source to prevent over-pressurizing and possible damage to the ductwork.

**▲ WARNING**

Before beginning any service, disconnect all power to the drive. Be aware that high voltages are present in the drive even after power has been disconnected. Capacitors within the drive must be allowed to discharge before beginning service.

**'VFD-Ready' For Customer-installation**

Units configured as 'VFD-ready' provide provisions for a customer-installed drive. The physical dimensions of VFDs can vary greatly among manufacturers, horsepower ratings and voltage requirements. Keep in mind that drive manufacturers also require various minimum clearances to allow for adequate internal cooling of the drive during operation.

The unit comes with a mounting bracket installed in the Blower Access compartment which may accommodate other vendor's drives depending on their size. In order to utilize the unit's mounting bracket, the maximum recommended drive dimensions are as follows:

For 5-hp motor applications .....13" H x 6" W x 7" D  
 For 7.5 thru 15-hp motor applications .....13" H x 8" W x 8" D

If the drive will not fit in the allotted space, then it will need to be mounted elsewhere; either within the building on a perpendicular wall which is not subjected to excessive temperature, vibration, humidity, dust, corrosive gas, explosive gas, etc., or within an appropriate enclosure rated for outside installation to safeguard against moisture, dust and excessive heat.

The power leads to the drive (L1, L2, L3) and from the motor (T1, T2, T3) along with the respective ground wires are supplied with the unit and need to be connected after the drive is installed.

**▲ CAUTION**

Do not connect AC power to the T1, T2, T3 drive terminals to prevent damage to the VFD.

A terminal block located in the control box is provided for field connection of the VFD speed reference signal (2-10 VDC) and to the normally-open, run-permit auxiliary contact. The use of shielded cable is recommended for the above control wiring connections.

**Optional Hot Gas Bypass (HGBP)**

To allow for low cooling load operation, a direct-acting, pressure-modulating bypass control valve installed on the system #1 discharge line is used to divert high temperature, high pressure refrigerant around the TXV in order to maintain a desired minimum evaporator pressure.

The opening pressure of the bypass valve is fully adjustable between 0 and 80 psig with a factory-setting of 60 psig. HGBP is standard on all units with VAV and optional with CV units.

## Phasing

York® Model ZJ units are properly phased at the factory. Check for proper compressor rotation. If the blower or compressors rotate in the wrong direction at start-up, the electrical connection to the unit is misphased. Change the phasing of the **Field Line Connection at the factory or field supplied disconnect** to obtain proper rotation. (Scroll compressors operate in only one direction. If the scroll is drawing low amperage, has similar suction and discharge pressures, or producing a high noise level, the scroll is misphased.)

### CAUTION

Scroll compressors require proper rotation to operate correctly. Units are properly phased at the factory. Do not change the internal wiring to make the blower condenser fans, or compressor rotate correctly.

## Blower Rotation

Check for proper supply air blower rotation. If the blower is rotating backwards, the line voltage at the unit point of power connection is misphased (See 'PHASING').

## Belt Tension

The tension on the belt should be adjusted as shown in Figure 17.

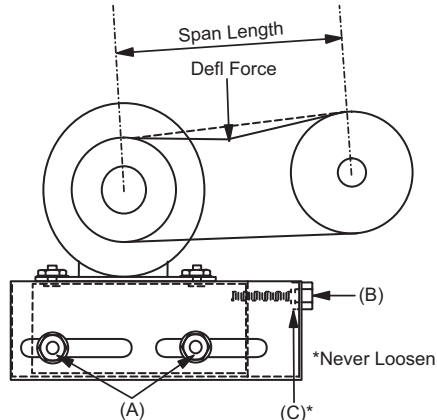

Figure 17: Belt Adjustment

### CAUTION

Procedure for adjusting belt tension:

1. Loosen four nuts (top and bottom) A.
2. Adjust by turning (B).
3. Never loosen nuts (C).
4. Use belt tension checker to apply a perpendicular force to one belt at the midpoint of the span as shown. Deflection distance of 4mm (5/32") is obtained.

To determine the deflection distance from normal position, use a straight edge from sheave to sheave as reference line. The recommended deflection force is as follows:

Tension new belts at the max. deflection force recommended for the belt section. Check the belt tension at least two times during the first 24 hours of operation. Any retensioning should fall between the min. and max. deflection force values.

5. After adjusting re-tighten nuts (A).

## CFM Static Pressure and Power-Altitude and Temperature Corrections

The information below should be used to assist in application of product when being applied at altitudes at or exceeding 1000 feet above sea level.

The air flow rates listed in the standard blower performance tables are based on standard air at sea level. As the altitude or temperature increases, the density of air decreases. In order to use the indoor blower tables for high altitude applications, certain corrections are necessary.

A centrifugal fan is a "constant volume" device. This means that, if the rpm remains constant, the CFM delivered is the same regardless of the density of the air. However, since the air at high altitude is less dense, less static pressure will be generated and less power will be required than a similar application at sea level. Air density correction factors are shown in Table 15 and Figure 18.

**Table 15: Altitude/Temperature Correction Factors**

Air Temp.	Altitude (Ft.)										
	0	1000	2000	3000	4000	5000	6000	7000	8000	9000	10000
40	1.060	1.022	0.986	0.950	0.916	0.882	0.849	0.818	0.788	0.758	0.729
50	1.039	1.002	0.966	0.931	0.898	0.864	0.832	0.802	0.772	0.743	0.715
60	1.019	0.982	0.948	0.913	0.880	0.848	0.816	0.787	0.757	0.729	0.701
70	1.000	0.964	0.930	0.896	0.864	0.832	0.801	0.772	0.743	0.715	0.688
80	0.982	0.947	0.913	0.880	0.848	0.817	0.787	0.758	0.730	0.702	0.676
90	0.964	0.929	0.897	0.864	0.833	0.802	0.772	0.744	0.716	0.689	0.663
100	0.946	0.912	0.880	0.848	0.817	0.787	0.758	0.730	0.703	0.676	0.651

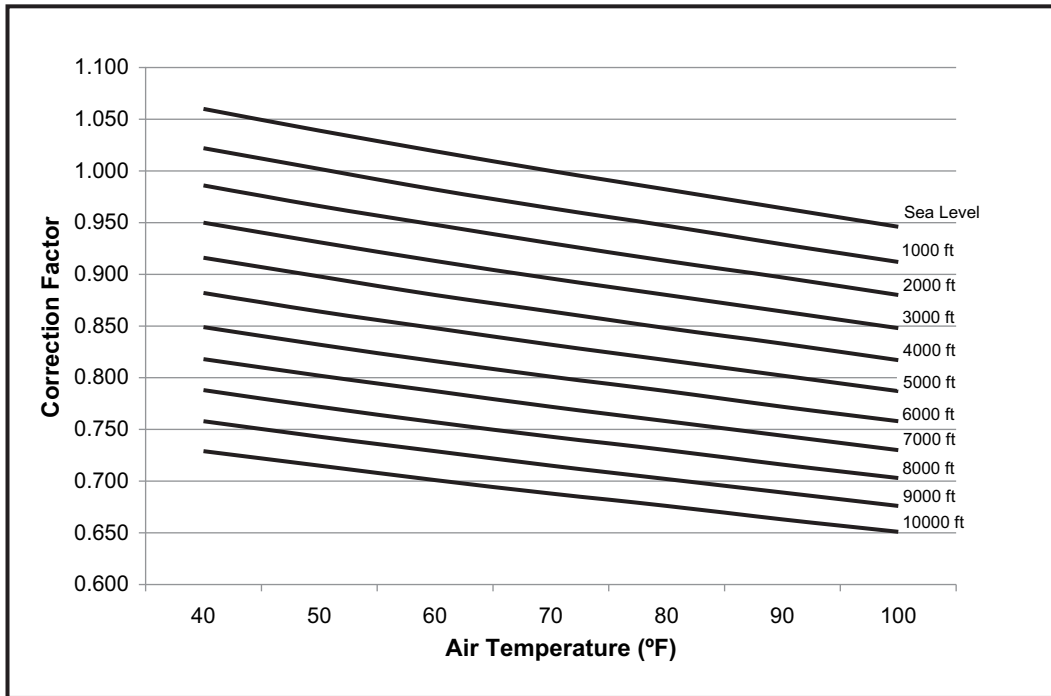

**Figure 18: Altitude/Temperature Correction Factors**

The examples below will assist in determining the airflow performance of the product at altitude.

**Example 1:** What are the corrected CFM, static pressure, and BHP at an elevation of 5,000 ft. if the blower performance data is 6,000 CFM, 1.5 IWC and 4.0 BHP?

**Solution:** At an elevation of 5,000 ft. the indoor blower will still deliver 6,000 CFM if the rpm is unchanged. However, Table 15 must be used to determine the static pressure and BHP. Since no temperature data is given, we will assume an air temperature of 70°F. Table 15 shows the correction factor to be 0.832.

$$\text{Corrected static pressure} = 1.5 \times 0.832 = 1.248 \text{ IWC}$$

$$\text{Corrected BHP} = 4.0 \times 0.832 = 3.328$$

**Example 2:** A system, located at 5,000 feet of elevation, is to deliver 6,000 CFM at a static pressure of 1.5". Use the unit

blower tables to select the blower speed and the BHP requirement.

**Solution:** As in the example above, no temperature information is given so 70°F is assumed.

The 1.5" static pressure given is at an elevation of 5,000 ft. The first step is to convert this static pressure to equivalent sea level conditions.

$$\text{Sea level static pressure} = 1.5 / .832 = 1.80"$$

Enter the blower table at 6000 sCFM and static pressure of 1.8". The rpm listed will be the same rpm needed at 5,000 ft.

Suppose that the corresponding BHP listed in the table is 3.2. This value must be corrected for elevation.

$$\text{BHP at 5,000 ft.} = 3.2 \times .832 = 2.66$$

**Drive Selection**

1. Determine side or bottom supply duct application.
2. Determine desired airflow
3. Calculate or measure the amount of external static pressure.
4. Using the operating point determined from steps 1, 2 & 3, locate this point on the appropriate supply air blower performance table. (Linear interpolation may be necessary.)
5. Noting the RPM and BHP from step 4, locate the appropriate motor and/or drive on the RPM selection table.
6. Review the BHP compared to the motor options available. Select the appropriate motor and/or drive.
7. Review the RPM range for the motor options available. Select the appropriate drive if multiple drives are available for the chosen motor.
8. Determine turns open to obtain the desired operation point.

**Example**

1. 6800 CFM
2. 2.0 iwg
3. Using the supply air blower performance table below, the following data point was located: 1020 RPM & 5.92 BHP.
4. Using the RPM selection table below, Size X and Model Y is found.
5. 5.92 BHP exceeds the maximum continuous BHP rating of the 5.0 HP motor. The 7.5 HP motor is required.
6. 1020 RPM is within the range of the 7.5 HP drives.
7. Using the 7.5 HP motor and drive, 3.5 turns open will achieve 1020 RPM.

**Example Supply Air Blower Performance**

Air Flow (CFM)	Available External Static Pressure - IWG																							
	0.4		0.6		0.8		1.0		1.2		1.4		1.6		1.8		2.0		2.2		2.4		2.6	
	RPM	BHP	RPM	BHP	RPM	BHP	RPM	BHP	RPM	BHP	RPM	BHP	RPM	BHP	RPM	BHP	RPM	BHP	RPM	BHP	RPM	BHP	RPM	BHP
	Standard 5 HP & Field Supplied Drive		Standard 5 HP & Drive								High Static 7.5 HP & Drive													
6400	719	2.55	756	3.03	792	3.49	828	3.92	864	4.32	899	4.67	933	4.98	966	5.24	998	5.45	1028	5.59	1056	5.67	1083	5.68
6800	742	3.02	778	3.51	814	3.97	850	4.40	886	4.79	921	5.15	955	5.46	988	5.72	1020	5.92	1050	6.07	1078	6.15	1105	6.16
7200	765	3.54	802	4.03	838	4.49	874	4.92	910	5.32	945	5.67	979	5.98	1012	6.24	1044	6.44	1074	6.59	1102	6.67	1129	6.68
7600	790	4.11	827	4.60	863	5.06	899	5.49	935	5.88	970	6.24	1004	6.55	1037	6.81	1069	7.01	1099	7.16	1127	7.24	1154	7.25
																					7.5 HP & Field Supplied Drive			

**Table X: RPM Selection**

Size (Tons)	Model	HP	Max BHP	Motor Sheave	Blower Sheave	6 Turns Open	5 Turns Open	4 Turns Open	3 Turns Open	2 Turns Open	1 Turn Open	Fully Closed
X	Y	5	5.75	1VP60	BK110	730	765	800	835	870	905	N/A
		7.5	8.63	1VP60	BK090	905	950	990	1035	1075	1120	N/A

**Table 16: Air Flow Performance - Side Duct Application**  
**ZJ180 (15 Ton) Side Duct**

Air Flow (CFM)	Available External Static Pressure - IWG <sup>1</sup>																							
	0.4		0.6		0.8		1.0		1.2		1.4		1.6		1.8		2.0		2.2		2.4		2.6	
	RPM	BHP	RPM	BHP	RPM	BHP	RPM	BHP	RPM	BHP	RPM	BHP	RPM	BHP	RPM	BHP	RPM	BHP	RPM	BHP	RPM	BHP	RPM	BHP
	Standard 5 HP & Field Supplied Drive						Standard 5 HP & Drive						High Static 5 HP & Drive											
4000	727	1.14	765	1.47	806	1.77	848	2.04	891	2.29	934	2.52	977	2.73	1020	2.93	1061	3.12	1101	3.30	1138	3.48	1174	3.67
4400	753	1.51	792	1.84	832	2.14	874	2.41	917	2.66	960	2.88	1004	3.09	1046	3.29	1087	3.48	1127	3.67	1165	3.85	1200	4.03
4800	781	1.92	820	2.25	861	2.55	903	2.82	946	3.06	989	3.29	1032	3.50	1074	3.70	1116	3.89	1155	4.08	1193	4.26	1228	4.44
5200	812	2.37	850	2.70	891	3.00	933	3.27	976	3.52	1019	3.74	1062	3.95	1105	4.15	1146	4.34	1186	4.53	1223	4.71	1259	4.89
5600	844	2.86	882	3.19	923	3.49	965	3.76	1008	4.01	1051	4.23	1094	4.45	1137	4.64	1178	4.83	1218	5.02	1255	5.20	1291	5.39
6000	877	3.39	916	3.72	957	4.02	999	4.29	1042	4.54	1085	4.76	1128	4.98	1170	5.17	1212	5.36	1251	5.55	1289	5.73	-	-
6400	912	3.96	951	4.29	992	4.59	1034	4.86	1077	5.10	1120	5.33	1163	5.54	1205	5.74	-	-	-	-	-	-	-	-
6800	949	4.56	988	4.89	1028	5.19	1070	5.46	1113	5.71	-	-	-	-	-	-	-	-	-	-	-	-	-	-
7200	986	5.20	1025	5.53	-	-	-	-	-	-	-	-	-	-	-	-	-	-	-	-	-	-	-	-

5 HP & Field Supplied Drive

1. Blower performance includes gas heat exchangers and 2" filters. See STATIC RESISTANCE table for additional applications.
2. See RPM SELECTION table to determine desired motor sheave setting and to determine the maximum continuous BHP.
3. kW = BHP x 0.898.

**ZJ210 (17.5 Ton) Side Duct**

Air Flow (CFM)	Available External Static Pressure - IWG <sup>1</sup>																							
	0.4		0.6		0.8		1.0		1.2		1.4		1.6		1.8		2.0		2.2		2.4		2.6	
	RPM	BHP	RPM	BHP	RPM	BHP	RPM	BHP	RPM	BHP	RPM	BHP	RPM	BHP	RPM	BHP	RPM	BHP	RPM	BHP	RPM	BHP	RPM	BHP
	Standard 5 HP & Field Supplied Drive						Standard 5 HP & Drive						High Static 7.5 HP & Drive											
4400	636	0.65	672	1.14	709	1.60	745	2.03	780	2.43	815	2.78	849	3.09	882	3.35	914	3.55	944	3.70	973	3.78	999	3.79
4800	649	0.99	685	1.48	721	1.94	757	2.37	793	2.77	828	3.12	862	3.43	895	3.69	927	3.89	957	4.04	985	4.12	1012	4.13
5200	663	1.34	700	1.83	736	2.29	772	2.72	808	3.11	843	3.47	877	3.78	910	4.04	942	4.24	972	4.39	1000	4.47	1027	4.48
5600	680	1.71	717	2.20	753	2.66	789	3.09	825	3.48	860	3.84	894	4.15	927	4.41	959	4.61	989	4.76	1017	4.84	1044	4.85
6000	699	2.11	735	2.60	772	3.06	808	3.49	844	3.88	879	4.24	913	4.55	946	4.80	977	5.01	1007	5.15	1036	5.24	1062	5.25
6400	719	2.55	756	3.03	792	3.49	828	3.92	864	4.32	899	4.67	933	4.98	966	5.24	998	5.45	1028	5.59	1056	5.67	1083	5.68
6800	742	3.02	778	3.51	814	3.97	850	4.40	886	4.79	921	5.15	955	5.46	988	5.72	1020	5.92	1050	6.07	1078	6.15	1105	6.16
7200	765	3.54	802	4.03	838	4.49	874	4.92	910	5.32	945	5.67	979	5.98	1012	6.24	1044	6.44	1074	6.59	1102	6.67	1129	6.68
7600	790	4.11	827	4.60	863	5.06	899	5.49	935	5.88	970	6.24	1004	6.55	1037	6.81	1069	7.01	1099	7.16	1127	7.24	1154	7.25
8000	817	4.72	853	5.21	890	5.67	926	6.10	962	6.50	997	6.85	1031	7.16	1064	7.42	1095	7.62	1125	7.77	1154	7.85	1180	7.86
8400	845	5.38	881	5.87	918	6.33	954	6.76	990	7.16	1025	7.51	1059	7.82	1092	8.08	1123	8.28	1153	8.43	1182	8.51	1208	8.52
8800	874	6.09	911	6.58	947	7.04	983	7.47	1019	7.86	1054	8.22	1088	8.53	-	-	-	-	-	-	-	-	-	-

7.5 HP & Field Supplied Drive

1. Blower performance includes gas heat exchangers and 2" filters. See STATIC RESISTANCE table for additional applications.
2. See RPM SELECTION table to determine desired motor sheave setting and to determine the maximum continuous BHP.
3. kW = BHP x 0.838.



**ZJ240 (20 Ton) Side Duct**

Air Flow (CFM)	Available External Static Pressure - IWG <sup>1</sup>																									
	0.4		0.6		0.8		1.0		1.2		1.4		1.6		1.8		2.0		2.2		2.4		2.6			
	RPM	BHP	RPM	BHP	RPM	BHP	RPM	BHP	RPM	BHP	RPM	BHP	RPM	BHP	RPM	BHP	RPM	BHP	RPM	BHP	RPM	BHP	RPM	BHP	RPM	BHP
	Standard 5 HP & Field Supplied Drive				Standard 5 HP & Drive								High Static 7.5 HP & Drive													
5200	663	1.34	700	1.83	736	2.29	772	2.72	808	3.11	843	3.47	877	3.78	910	4.04	942	4.24	972	4.39	1000	4.47	1027	4.48		
5600	680	1.71	717	2.20	753	2.66	789	3.09	825	3.48	860	3.84	894	4.15	927	4.41	959	4.61	989	4.76	1017	4.84	1044	4.85		
6000	699	2.11	735	2.60	772	3.06	808	3.49	844	3.88	879	4.24	913	4.55	946	4.80	977	5.01	1007	5.15	1036	5.24	1062	5.25		
6400	719	2.55	756	3.03	792	3.49	828	3.92	864	4.32	899	4.67	933	4.98	966	5.24	998	5.45	1028	5.59	1056	5.67	1083	5.68		
6800	742	3.02	778	3.51	814	3.97	850	4.40	886	4.79	921	5.15	955	5.46	988	5.72	1020	5.92	1050	6.07	1078	6.15	1105	6.16		
7200	765	3.54	802	4.03	838	4.49	874	4.92	910	5.32	945	5.67	979	5.98	1012	6.24	1044	6.44	1074	6.59	1102	6.67	1129	6.68		
7600	790	4.11	827	4.60	863	5.06	899	5.49	935	5.88	970	6.24	1004	6.55	1037	6.81	1069	7.01	1099	7.16	1127	7.24	1154	7.25		
8000	817	4.72	853	5.21	890	5.67	926	6.10	962	6.50	997	6.85	1031	7.16	1064	7.42	1095	7.62	1125	7.77	1154	7.85	1180	7.86		
8400	845	5.38	881	5.87	918	6.33	954	6.76	990	7.16	1025	7.51	1059	7.82	1092	8.08	1123	8.28	1153	8.43	1182	8.51	1208	8.52		
8800	874	6.09	911	6.58	947	7.04	983	7.47	1019	7.86	1054	8.22	1088	8.53	-	-	-	-	-	-	-	-	-	-		
9200	905	6.85	941	7.33	977	7.79	1014	8.22	1049	8.62	-	-	-	-	-	-	-	-	-	-	-	-	-	-		
9600	936	7.65	973	8.13	1009	8.59	-	-	-	-	-	-	-	-	-	-	-	-	-	-	-	-	-	-		
10000	969	8.49	-	-	-	-	-	-	-	-	-	-	-	-	-	-	-	-	-	-	-	-	-	-		
	7.5 HP & Field Supplied Drive																									

- Blower performance includes gas heat exchangers and 2" filters. See STATIC RESISTANCE table for additional applications.
- See RPM SELECTION table to determine desired motor sheave setting and to determine the maximum continuous BHP.
- $\text{kW} = \text{BHP} \times 0.838$ .

**ZJ300 (25 Ton) Side Duct**

Air Flow (CFM)	Available External Static Pressure - IWG <sup>1</sup>															
	0.4		0.6		0.8		1.0		1.2		1.4		1.6		1.8	
	RPM	BHP	RPM	BHP	RPM	BHP	RPM	BHP	RPM	BHP	RPM	BHP	RPM	BHP	RPM	BHP
	Low Static 7.5 HP & Field Supplied Drive								Low Static 7.5 HP & Drive							
6600	760	2.51	793	3.11	824	3.68	856	4.23	887	4.74	919	5.23	950	5.70	983	6.15
7000	775	2.99	808	3.60	839	4.17	871	4.71	902	5.22	934	5.72	966	6.19	998	6.64
7400	792	3.51	824	4.11	856	4.69	887	5.23	918	5.74	950	6.24	982	6.70	1014	7.16
7800	809	4.07	841	4.67	873	5.24	904	5.78	935	6.30	967	6.79	999	7.26	1031	7.71
8200	826	4.66	859	5.27	890	5.84	922	6.38	953	6.89	985	7.39	1016	7.86	1049	8.31
8600	845	5.30	877	5.90	909	6.47	940	7.01	972	7.53	1003	8.02	1035	8.49	1067	8.94
9000	864	5.97	896	6.57	928	7.14	960	7.69	991	8.20	1022	8.69	1054	9.16	1087	9.61
9400	884	6.68	916	7.28	948	7.86	980	8.40	1011	8.91	1042	9.41	1074	9.88	1107	10.33
9800	905	7.43	937	8.04	969	8.61	1000	9.15	1032	9.67	1063	10.16	1095	10.63	1127	11.08
10200	926	8.22	958	8.83	990	9.40	1021	9.94	1053	10.46	1084	10.95	1116	11.42	1148	11.87
10600	948	9.05	980	9.66	1012	10.23	1043	10.77	1075	11.29	1106	11.78	1138	12.25	1170	12.70
11000	970	9.92	1003	10.52	1034	11.09	1066	11.64	1097	12.15	1128	12.64	1160	13.11	1193	13.56
11400	993	10.82	1025	11.43	1057	12.00	1089	12.54	1120	13.06	1151	13.55	1183	14.02	1216	14.47
11800	1017	11.76	1049	12.37	1081	12.94	1112	13.48	1143	14.00	1175	14.49	1207	14.96	1239	15.41
12200	1040	12.74	1073	13.34	1104	13.91	1136	14.46	1167	14.97	1199	15.46	1231	15.93	1263	16.38
12600	1065	13.75	1097	14.35	1129	14.92	1160	15.47	1192	15.98	1223	16.47	1255	16.94	-	-
	High Static 15 HP & Drive															

Standard 10 HP & Drive

Air Flow (CFM)	Available External Static Pressure - IWG <sup>1</sup>															
	2.0		2.2		2.4		2.6		2.8		3.0		3.2		3.4	
	RPM	BHP	RPM	BHP	RPM	BHP	RPM	BHP	RPM	BHP	RPM	BHP	RPM	BHP	RPM	BHP
	Standard 10 HP & Drive								High Static 15 HP & Drive							
6600	1016	6.59	1050	7.00	1086	7.41	1123	7.81	1161	8.19	1202	8.58	1244	8.95	1289	9.33
7000	1031	7.07	1065	7.49	1101	7.89	1138	8.29	1176	8.68	1217	9.06	1259	9.44	1304	9.82
7400	1047	7.59	1081	8.01	1117	8.41	1154	8.81	1192	9.20	1233	9.58	1275	9.96	1320	10.34
7800	1064	8.14	1098	8.56	1134	8.97	1171	9.36	1209	9.75	1250	10.13	1292	10.51	1337	10.89
8200	1082	8.74	1116	9.16	1152	9.56	1189	9.96	1227	10.35	1268	10.73	1310	11.11	1355	11.49
8600	1101	9.37	1135	9.79	1170	10.20	1207	10.59	1246	10.98	1286	11.36	1329	11.74	1374	12.12
9000	1120	10.05	1154	10.46	1189	10.87	1226	11.27	1265	11.65	1305	12.04	1348	12.41	1393	12.79
9400	1140	10.76	1174	11.18	1209	11.58	1246	11.98	1285	12.37	1325	12.75	1368	13.13	1413	13.51
9800	1160	11.51	1195	11.93	1230	12.33	1267	12.73	1306	13.12	1346	13.50	1389	13.88	1434	14.26
10200	1182	12.30	1216	12.72	1251	13.12	1288	13.52	1327	13.91	1367	14.29	1410	14.67	1455	15.05
10600	1204	13.13	1238	13.55	1273	13.95	1310	14.35	1349	14.74	1389	15.12	1432	15.50	1477	15.88
11000	1226	14.00	1260	14.41	1296	14.82	1332	15.22	1371	15.60	1412	15.99	1454	16.36	1499	16.74
11400	1249	14.90	1283	15.32	1318	15.72	1355	16.12	1394	16.51	1434	16.89	-	-	-	-
11800	1272	15.84	1306	16.26	1342	16.66	1379	17.06	-	-	-	-	-	-	-	-
12200	1296	16.82	1330	17.23	-	-	-	-	-	-	-	-	-	-	-	-
12600	-	-	-	-	-	-	-	-	-	-	-	-	-	-	-	-
	15 HP & Field Supplied Drive															

1. Blower performance includes gas heat exchangers and 2" filters. See STATIC RESISTANCE table for additional applications.
2. See RPM SELECTION table to determine desired motor sheave setting and to determine the maximum continuous BHP.
3. kW = BHP x 0.82.

**Table 17: Air Flow Performance - Bottom Duct Application**

**ZJ180 (15 Ton) Bottom Duct**

Air Flow (CFM)	Available External Static Pressure - IWG <sup>1</sup>																									
	0.4		0.6		0.8		1.0		1.2		1.4		1.6		1.8		2.0		2.2		2.4		2.6			
	RPM	BHP	RPM	BHP	RPM	BHP	RPM	BHP	RPM	BHP	RPM	BHP	RPM	BHP	RPM	BHP	RPM	BHP	RPM	BHP	RPM	BHP	RPM	BHP	RPM	BHP
	Standard 5 HP & Field Supplied Drive				Standard 5 HP & Drive								High Static 5 HP & Drive													
4000	768	1.24	806	1.55	846	1.83	888	2.09	930	2.32	972	2.53	1015	2.73	1056	2.91	1097	3.09	1136	3.27	1173	3.44	1208	3.61		
4400	797	1.65	835	1.96	875	2.24	916	2.49	959	2.72	1001	2.93	1043	3.13	1085	3.32	1126	3.50	1165	3.67	1202	3.84	1237	4.02		
4800	828	2.09	866	2.40	906	2.68	947	2.93	989	3.16	1032	3.38	1074	3.58	1116	3.76	1157	3.94	1196	4.11	1233	4.28	1267	4.46		
5200	860	2.57	898	2.88	938	3.16	980	3.41	1022	3.65	1064	3.86	1107	4.06	1148	4.24	1189	4.42	1228	4.59	1265	4.77	1300	4.94		
5600	894	3.09	932	3.40	972	3.68	1014	3.93	1056	4.16	1098	4.38	1141	4.57	1182	4.76	1223	4.94	1262	5.11	1299	5.28	1334	5.46		
6000	930	3.64	968	3.95	1008	4.23	1049	4.48	1091	4.71	1134	4.93	1176	5.12	1218	5.31	1259	5.49	1298	5.66	-	-	-	-	-	-
6400	966	4.22	1005	4.53	1045	4.81	1086	5.06	1128	5.30	1171	5.51	1213	5.71	-	-	-	-	-	-	-	-	-	-	-	-
6800	1005	4.84	1043	5.14	1083	5.42	1124	5.68	-	-	-	-	-	-	-	-	-	-	-	-	-	-	-	-	-	-
7200	1044	5.48	-	-	-	-	-	-	-	-	-	-	-	-	-	-	-	-	-	-	-	-	-	-	-	-
	5 HP & Field Supplied Drive																									

1. Blower performance includes gas heat exchangers and 2" filters. See STATIC RESISTANCE table for additional applications.
2. See RPM SELECTION table to determine desired motor sheave setting and to determine the maximum continuous BHP.
3. kW = BHP x 0.898.

**ZJ210 (17.5 Ton) Bottom Duct**

Air Flow (CFM)	Available External Static Pressure - IWG <sup>1</sup>																									
	0.4		0.6		0.8		1.0		1.2		1.4		1.6		1.8		2.0		2.2		2.4		2.6			
	RPM	BHP	RPM	BHP	RPM	BHP	RPM	BHP	RPM	BHP	RPM	BHP	RPM	BHP	RPM	BHP	RPM	BHP	RPM	BHP	RPM	BHP	RPM	BHP	RPM	BHP
	Standard 5 HP & Field Supplied Drive				Standard 5 HP & Drive								High Static 7.5 HP & Drive													
4400	661	0.74	697	1.19	733	1.62	768	2.03	803	2.40	838	2.73	871	3.02	904	3.26	935	3.45	964	3.59	992	3.66	1018	3.67		
4800	677	1.07	712	1.53	748	1.96	784	2.36	819	2.73	853	3.06	887	3.35	919	3.59	950	3.79	980	3.92	1008	4.00	1034	4.01		
5200	694	1.43	730	1.89	766	2.32	801	2.72	836	3.09	871	3.42	904	3.71	937	3.95	968	4.14	997	4.28	1025	4.35	1051	4.37		
5600	713	1.82	749	2.27	785	2.71	820	3.11	856	3.48	890	3.81	923	4.10	956	4.34	987	4.53	1017	4.67	1045	4.74	1071	4.75		
6000	734	2.25	770	2.70	806	3.13	841	3.53	877	3.90	911	4.23	944	4.52	977	4.77	1008	4.96	1038	5.09	1066	5.17	1092	5.18		
6400	757	2.71	793	3.17	829	3.60	864	4.00	899	4.37	934	4.70	967	4.99	1000	5.23	1031	5.42	1060	5.56	1088	5.64	1114	5.65		
6800	781	3.22	817	3.68	853	4.11	888	4.51	923	4.88	958	5.21	991	5.50	1024	5.74	1055	5.94	1085	6.07	1112	6.15	1139	6.16		
7200	807	3.78	843	4.23	878	4.66	914	5.07	949	5.44	983	5.77	1017	6.06	1049	6.30	1081	6.49	1110	6.63	1138	6.70	1164	6.71		
7600	834	4.38	870	4.83	905	5.26	941	5.67	976	6.04	1010	6.37	1044	6.66	1076	6.90	1108	7.09	1137	7.23	1165	7.30	1191	7.31		
8000	862	5.02	898	5.48	934	5.91	969	6.31	1004	6.68	1039	7.01	1072	7.30	1105	7.55	1136	7.74	1166	7.87	1194	7.95	1220	7.96		
8400	892	5.71	928	6.17	963	6.60	999	7.00	1034	7.37	1069	7.70	1102	7.99	1134	8.24	1166	8.43	1195	8.56	-	-	-	-	-	-
8800	923	6.45	959	6.91	994	7.34	1030	7.74	1065	8.11	1099	8.44	-	-	-	-	-	-	-	-	-	-	-	-	-	-
	7.5 HP & Field Supplied Drive																									

1. Blower performance includes gas heat exchangers and 2" filters. See STATIC RESISTANCE table for additional applications.
2. See RPM SELECTION table to determine desired motor sheave setting and to determine the maximum continuous BHP.
3. kW = BHP x 0.838.

**ZJ240 (20 Ton) Bottom Duct**

Air Flow (CFM)	Available External Static Pressure - IWG <sup>1</sup>																							
	0.4		0.6		0.8		1.0		1.2		1.4		1.6		1.8		2.0		2.2		2.4		2.6	
	RPM	BHP	RPM	BHP	RPM	BHP	RPM	BHP	RPM	BHP	RPM	BHP	RPM	BHP	RPM	BHP	RPM	BHP	RPM	BHP	RPM	BHP	RPM	BHP
	Standard 5 HP & Drive												High Static 7.5 HP & Drive											
5200	694	1.43	730	1.89	766	2.32	801	2.72	836	3.09	871	3.42	904	3.71	937	3.95	968	4.14	997	4.28	1025	4.35	1051	4.37
5600	713	1.82	749	2.27	785	2.71	820	3.11	856	3.48	890	3.81	923	4.10	956	4.34	987	4.53	1017	4.67	1045	4.74	1071	4.75
6000	734	2.25	770	2.70	806	3.13	841	3.53	877	3.90	911	4.23	944	4.52	977	4.77	1008	4.96	1038	5.09	1066	5.17	1092	5.18
6400	757	2.71	793	3.17	829	3.60	864	4.00	899	4.37	934	4.70	967	4.99	1000	5.23	1031	5.42	1060	5.56	1088	5.64	1114	5.65
6800	781	3.22	817	3.68	853	4.11	888	4.51	923	4.88	958	5.21	991	5.50	1024	5.74	1055	5.94	1085	6.07	1112	6.15	1139	6.16
7200	807	3.78	843	4.23	878	4.66	914	5.07	949	5.44	983	5.77	1017	6.06	1049	6.30	1081	6.49	1110	6.63	1138	6.70	1164	6.71
7600	834	4.38	870	4.83	905	5.26	941	5.67	976	6.04	1010	6.37	1044	6.66	1076	6.90	1108	7.09	1137	7.23	1165	7.30	1191	7.31
8000	862	5.02	898	5.48	934	5.91	969	6.31	1004	6.68	1039	7.01	1072	7.30	1105	7.55	1136	7.74	1166	7.87	1194	7.95	1220	7.96
8400	892	5.71	928	6.17	963	6.60	999	7.00	1034	7.37	1069	7.70	1102	7.99	1134	8.24	1166	8.43	1195	8.56	-	-	-	-
8800	923	6.45	959	6.91	994	7.34	1030	7.74	1065	8.11	1099	8.44	-	-	-	-	-	-	-	-	-	-	-	-
9200	955	7.23	991	7.68	1026	8.11	1062	8.52	-	-	-	-	-	-	-	-	-	-	-	-	-	-	-	-
9600	988	8.05	1024	8.51	-	-	-	-	-	-	-	-	-	-	-	-	-	-	-	-	-	-	-	-

7.5 HP & Field Supplied Drive

1. Blower performance includes gas heat exchangers and 2" filters. See STATIC RESISTANCE table for additional applications.
2. See RPM SELECTION table to determine desired motor sheave setting and to determine the maximum continuous BHP.
3. kW = BHP x 0.838.

**ZJ300 (25 Ton) Bottom Duct**

Air Flow (CFM)	Available External Static Pressure - IWG <sup>1</sup>													
	0.4		0.6		0.8		1.0		1.2		1.4		1.6	
	RPM	BHP	RPM	BHP	RPM	BHP	RPM	BHP	RPM	BHP	RPM	BHP	RPM	BHP
	Low Static 7.5 HP & Field Supplied Drive													
6600	787	2.67	819	3.23	850	3.76	881	4.27	912	4.75	943	5.21	974	5.65
7000	804	3.18	835	3.74	867	4.27	898	4.78	928	5.26	959	5.72	991	6.16
7400	821	3.72	853	4.28	884	4.82	915	5.32	946	5.80	977	6.26	1008	6.70
7800	839	4.30	871	4.86	902	5.40	933	5.90	964	6.39	995	6.85	1026	7.28
8200	858	4.92	890	5.48	921	6.02	952	6.52	983	7.01	1013	7.47	1045	7.90
8600	877	5.58	909	6.14	940	6.68	971	7.18	1002	7.66	1033	8.12	1064	8.56
9000	898	6.28	929	6.84	960	7.37	991	7.88	1022	8.36	1053	8.82	1084	9.26
9400	918	7.01	950	7.57	981	8.10	1012	8.61	1043	9.09	1074	9.55	1105	9.99
9800	940	7.78	972	8.34	1003	8.87	1034	9.38	1064	9.86	1095	10.32	1127	10.76
10200	962	8.58	994	9.14	1025	9.68	1056	10.18	1086	10.67	1117	11.13	1149	11.56
10600	984	9.42	1016	9.98	1047	10.52	1078	11.02	1109	11.51	1140	11.96	1171	12.40
11000	1007	10.30	1039	10.86	1070	11.39	1101	11.90	1132	12.38	1163	12.84	1194	13.28
11400	1031	11.20	1063	11.76	1094	12.30	1125	12.80	1156	13.29	1187	13.75	1218	14.18
11800	1055	12.14	1087	12.70	1118	13.24	1149	13.74	1180	14.23	1211	14.69	1242	15.12
12200	1080	13.11	1111	13.68	1142	14.21	1173	14.72	1204	15.20	1235	15.66	1266	16.10
12600	1104	14.12	1136	14.68	1167	15.21	1198	15.72	1229	16.20	1260	16.66	1291	17.10
	High Static 15 HP & Drive													

Standard 10 HP & Drive

Air Flow (CFM)	Available External Static Pressure - IWG <sup>1</sup>																	
	1.8		2.0		2.2		2.4		2.6		2.8		3.0		3.2		3.4	
	RPM	BHP	RPM	BHP	RPM	BHP	RPM	BHP	RPM	BHP	RPM	BHP	RPM	BHP	RPM	BHP	RPM	BHP
	Standard 10 HP & Drive										High Static 15 HP & Drive							
6600	1006	6.07	1039	6.48	1072	6.87	1107	7.25	1144	7.62	1182	7.98	1221	8.33	1263	8.68	1307	9.04
7000	1023	6.58	1055	6.98	1089	7.37	1124	7.75	1160	8.12	1198	8.48	1238	8.84	1280	9.19	1324	9.54
7400	1040	7.12	1072	7.53	1106	7.92	1141	8.30	1177	8.67	1215	9.03	1255	9.38	1297	9.74	1341	10.09
7800	1058	7.71	1090	8.11	1124	8.50	1159	8.88	1195	9.25	1233	9.61	1273	9.97	1315	10.32	1359	10.67
8200	1077	8.33	1109	8.73	1143	9.12	1178	9.50	1214	9.87	1252	10.23	1292	10.59	1334	10.94	1378	11.29
8600	1096	8.98	1129	9.39	1162	9.78	1197	10.16	1234	10.53	1272	10.89	1311	11.24	1353	11.60	1397	11.95
9000	1116	9.68	1149	10.08	1183	10.47	1218	10.85	1254	11.22	1292	11.58	1332	11.94	1373	12.29	1418	12.64
9400	1137	10.41	1170	10.82	1203	11.21	1238	11.59	1275	11.95	1313	12.32	1352	12.67	1394	13.02	1438	13.37
9800	1159	11.18	1191	11.59	1225	11.98	1260	12.35	1296	12.72	1334	13.09	1374	13.44	1416	13.79	1460	14.14
10200	1181	11.99	1213	12.39	1247	12.78	1282	13.16	1318	13.53	1356	13.89	1396	14.25	1438	14.60	1482	14.95
10600	1203	12.82	1236	13.23	1269	13.62	1304	14.00	1341	14.37	1379	14.73	1418	15.08	1460	15.44	1504	15.79
11000	1226	13.70	1259	14.10	1293	14.49	1327	14.87	1364	15.24	1402	15.60	1441	15.96	1483	16.31	1528	16.66
11400	1250	14.61	1282	15.01	1316	15.40	1351	15.78	1387	16.15	1425	16.51	1465	16.87	1507	17.22	-	-
11800	1274	15.55	1307	15.95	1340	16.34	1375	16.72	1411	17.09	-	-	-	-	-	-	-	-
12200	1298	16.52	1331	16.92	-	-	-	-	-	-	-	-	-	-	-	-	-	-
12600	-	-	-	-	-	-	-	-	-	-	-	-	-	-	-	-	-	-
	15 HP & Field Supplied Drive																	

1. Blower performance includes gas heat exchangers and 2" filters. See STATIC RESISTANCE table for additional applications.
2. See RPM SELECTION table to determine desired motor sheave setting and to determine the maximum continuous BHP.
3. kW = BHP x 0.82.

**Table 18: RPM Selection**

Size (Tons)	Model	HP	Max BHP	Motor Sheave	Blower Sheave	6 Turns Open	5 Turns Open	4 Turns Open	3 Turns Open	2 Turns Open	1 Turn Open	Fully Closed
180 (15)	ZJ	5	5.75	1VP65	BK110	815	850	885	920	950	985	N/A
		5	5.75	1VP65	BK090	1010	1055	1095	1135	1180	1220	N/A
210 (17.5)	ZJ	5	5.75	1VP60	BK110	730	765	800	835	870	905	N/A
		7.5	8.63	1VP60	BK090	905	950	990	1035	1075	1120	N/A
240 (20)	ZJ	5	5.75	1VP60	BK110	730	765	800	835	870	905	N/A
		7.5	8.63	1VP60	BK090	905	950	990	1035	1075	1120	N/A
300 (25)	ZJ	7.5	8.63	1VP60	1B5V94	810	850	885	920	960	1000	N/A
		10	11.50	1VP75X	1B5V110	975	1005	1040	1070	1100	1135	1165
		15	17.25	1VP75X	1B5V94	1140	1180	1215	1255	1290	1330	1365

**Table 19: Indoor Blower Specifications**

Size (Tons)	Model	Motor					Motor Sheave			Blower Sheave			Belt
		HP	RPM	Eff.	SF	Frame	Datum Dia. (in.)	Bore (in.)	Model	Datum Dia. (in.)	Bore (in.)	Model	
180 (15)	ZJ	5	1725	0.89	1.15	184T	5.2 - 6.4	1 1/8	1VP65	10.4	1	BK110	BX83
		5	1725	0.89	1.15	184T	5.2 - 6.4	1 1/8	1VP65	8.4	1	BK090	BX81
210 (17.5)	ZJ	5	1725	0.89	1.15	184T	4.2 - 5.5	1 1/8	1VP60	10.4	1 3/16	BK110	BX78
		7.5	1725	0.91	1.15	213T	4.2 - 5.5	1 3/8	1VP60	8.4	1 3/16	BK090	BX75
240 (20)	ZJ	5	1725	0.89	1.15	184T	4.2 - 5.5	1 1/8	1VP60	10.4	1 3/16	BK110	BX78
		7.5	1725	0.91	1.15	213T	4.2 - 5.5	1 3/8	1VP60	8.4	1 3/16	BK090	BX75
300 (25)	ZJ	7.5	1725	0.91	1.15	213T	4.2 - 5.5	1 3/8	1VP60	9.5	1 7/16	1B5V94	BX78
		10	1725	0.89	1.15	215T	5.8 - 7.0	1 3/8	1VP75X	11.1	1 7/16	1B5V110	5VX840
		15	1725	0.91	1.15	254T	6.2 - 7.4	1 5/8	1VP75X	9.5	1 7/16	1B5V94	5VX860

**Table 20: Power Exhaust Specifications**

Voltage	Motor			Motor			CFM @ 0.1 ESP
	HP	RPM <sup>1</sup>	QTY	LRA	FLA	MCA	
208/230-1-60	3/4	1075	1	7.7	5.0	6.25	5250
460-1-60	3/4	1075	1	4.1	2.2	2.75	5250
575-1-60	3/4	1050	1	2.84	1.5	1.875	5250

1. Motors are multi-tapped and factory wired for high speed.

**Air Balance**

**CAUTION**

On VAV units be certain that the VFD drive is set to maximum output, exhaust dampers are closed and individual space damper boxes are full open.

VFD units with bypass must not be in bypass mode ('LINE' position) unless all individual space dampers are full open.

Start the supply air blower motor. Adjust the resistances in both the supply and the return air duct systems to balance the air distribution throughout the conditioned space. The job specifications may require that this balancing be done by someone other than the equipment installer.

To check the supply air CFM after the initial balancing has been completed:

1. Remove the two 5/16" dot plugs from the blower motor and the filter access panels shown in the Unit Dimensions and Rear View Clearances Figure 6.
2. Insert at least 8" of 1/4 inch tubing into each of these holes for sufficient penetration into the air flow on both sides of the indoor coil.

**NOTE:** The tubes must be inserted and held in a position perpendicular to the air flow so that velocity pressure will not affect the static pressure readings.

3. Using an inclined manometer, determine the pressure drop across a dry evaporator coil. Since the moisture on an evaporator coil may vary greatly, measuring the pressure drop across a wet coil under field conditions would be inaccurate. To assure a dry coil, the compressors should be deactivated while the test is being run.

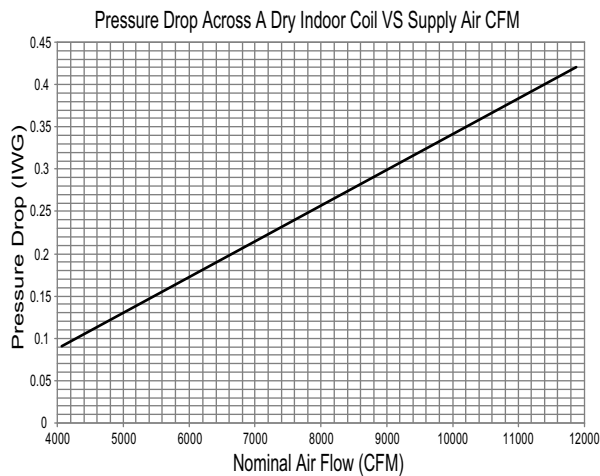

**Figure 19: Pressure Drop Across A Dry Indoor Coil Vs. Supply Air CFM For All Unit Tonnages**

4. Knowing the pressure drop across a dry coil, the actual CFM through the unit can be determined from the curve in Pressure Drop vs. Supply Air CFM Figure 19.

### WARNING

Failure to properly adjust the total system air quantity can result in extensive blower damage.

After readings have been obtained, remove the tubes and reinstall the two 5/16" dot plugs that were removed in Step 1.

**NOTE:** De-energize the compressors before taking any test measurements to assure a dry indoor coil.

### Supply Air Drive Adjustment

The RPM of the supply air blower will depend on the required CFM, the unit accessories or options and the static resistances of both the supply and the return air duct systems. With this information, the RPM for the supply air blower and the motor pulley adjustment (turns open) can be determined from the Blower Performance Data Tables.

### CAUTION

Belt drive blower systems **MUST** be adjusted to the specific static and CFM requirements for the application. The belt drive blowers are **NOT** set at the factory for any specific static or CFM. Adjustments of the blower speed and belt tension are **REQUIRED**. Tighten blower pulley and motor sheave set screws after these adjustments. Re-checking set screws after 10-12 hours run time is recommended.

High speed drive accessories (containing a smaller blower pulley and a shorter belt) are available for applications requiring the supply air blower to produce higher CFM's and/or higher static pressures. Use Model 1LD0460 for 15 ton units, Model 1LD0417 for 17.5 and 20 ton units, and Model 1LD0435 for 25 ton units. Refer to the Blower Motor and Drive Data Table 19.

Note the following:

1. The supply air CFM must be within the limitations shown in the Blower Performance Tables 16 and 17.
2. Pulleys can be adjusted in half turn increments.
3. The tension on the belt should be adjusted as shown in the Belt Adjustment, Figure 17.
4. Tighten blower pulley and motor sheave set screws after any adjustments. Re-check set screws after 10-12 hours run time recommended.

### Additional Static Resistance

Size (Tons)	Model	CFM	Cooling Only <sup>1</sup>	Economizer <sup>2 3</sup>	Electric Heat kW <sup>2</sup>			
					18	36	54	72
180 (15)	ZJ	4500	0.10	0.10	0.10	0.10	0.20	0.20
		6000	0.10	0.10	0.10	0.20	0.30	0.40
		7500	0.10	0.10	0.10	0.30	0.40	0.60
210 (17.5) 240 (20) 300 (25)	ZJ	6000	0.10	0.10	0.10	0.10	0.20	0.20
		7500	0.10	0.10	0.10	0.20	0.30	0.40
		9000	0.15	0.15	0.10	0.30	0.40	0.60
		10500	0.15	0.15	0.20	0.40	0.60	0.80
		12000	0.20	0.20	0.30	0.50	0.70	0.90

1. Add these values to the available static resistance in the respective Blower Performance Tables.
2. Deduct these values from the available external static pressure shown in the respective Blower Performance Tables.
3. The pressure drop through the economizer is greater for 100% outdoor air than for 100% return air. If the resistance of the return air duct is less than 0.25 IWG, the unit will deliver less CFM during full economizer operation.

## Sequence Of Operation

### Cooling Sequence of Operation

**NOTE:** For more in-depth sequence of operation of the Simplicity® SE control please refer to LIT-12011950 on [www.upgnet.com](http://www.upgnet.com) under Product Center \ Equipment Catalog \ Commercial Products \ Zoning Systems and Controls.

For ZJ units, a "Y1" call for the first stage of cooling is passed to the Unit Control Board (UCB) which then determines whether the requested operation is available and if so, which components to energize. With an "Y1" call for first stage cooling the UCB will determine if a first stage cooling output is valid as long as all safeties and time-delays allow a C1 output for cooling. The C1 relay on the UCB will close and send 24 volts to the M1 relay starting the first stage compressor and also energizing condenser fan relay RF1 (Cond. Fan #1) and if above 60°F, energizing condenser fan relay M4 (Cond. Fan #2). During any call for fan or cooling the FAN output on the UCB will energize the M3 relay starting the supply fan.

If a Y2 call is present it is passed to the Unit Control Board (UCB) which then determines whether the requested operation is available and if so, which components to energize. With an "Y2" call for second stage cooling the UCB will determine if a second stage cooling output is valid as long as all safeties and time-delays allow a C2 output for cooling. The C2 relay on the UCB will close and send 24v to the M2 relay starting the second stage compressor also energizing condenser fan relay RF1 (Cond. Fan #1) and if above 60°F, energizing condenser fan relay M4 (Cond. Fan #2). During any call for fan or cooling the FAN output on the UCB will energize the M3 relay starting the supply fan.

If a Y3 call is present it is passed to the Unit Control Board (UCB) which then determines whether the requested operation is available and if so, which components to energize. With an "Y3" call for third stage cooling the UCB will determine if a third stage cooling output is valid as long as all safeties and time-delays allow a C3 output for cooling. The C3 relay on the UCB will close and send 24v to the M7 relay starting the third stage compressor also energizing condenser fan relay RF2 (Cond. Fan #3) and if above 60°F, energizing condenser fan relay M6 (Cond. Fan #4). During any call for fan or cooling the FAN output on the UCB will energize the M3 relay starting the supply fan.

If a Y4 call is present it is passed to the Unit Control Board (UCB) which then determines whether the requested operation is available and if so, which components to energize. With an "Y4" call for fourth stage cooling the UCB will determine if a fourth stage cooling output is valid as long as all safeties and time-delays allow a C4 output for cooling. The C4 relay on the UCB will close and send 24v to the M8 relay starting the fourth stage compressor also energizing condenser fan relay RF2 (Cond. Fan #3) and if above 60°F, energizing condenser fan relay M6 (Cond. Fan #4). During any call for fan or cooling the FAN output on the UCB will energize the M3 relay starting the supply fan.

### Continuous Blower

By setting the room thermostat fan switch to "ON," the supply air blower will operate continuously.

### Intermittent Blower

With the room thermostat fan switch set to "AUTO" and the system switch set to either the "AUTO" or "HEAT" settings, the blower is energized whenever a cooling or heating operation is requested. The blower is energized after any specified delay associated with the operation.

When energized, the indoor blower has a minimum run time of 30 seconds. Additionally, the indoor blower has a minimum off delay of 10 seconds.

### Optional VAV Startup and Control

#### CAUTION

If the unit is operated with the manual bypass switch in the LINE (BYPASS) position and there are VAV boxes present in the duct system, then boxes must be driven to the full-open position using a customer-supplied power source to prevent over-pressurizing and possible damage to the ductwork.

For units with VFD and VAV control, the unit must first be put into the Occupied Mode to start operation. The default setting for all VAV units is 'Unoccupied', therefore the installer must add a jumper wire between terminals R - OCC on the VAV add-on board to put the unit into 'Occupied' Mode. Additionally, the unit can be switched between Unoccupied/Occupied mode through network communications with other BAS control systems.

Once placed into the Occupied Mode, the speed of the indoor blower motor is controlled by duct static pressure. The Duct Static set point (default = 1.5") is the pressure that the VFD drive will maintain when operating the unit in VAV mode. If the duct static pressure reaches or exceeds the high-limit set-point (default = 4.5"), then the supply fan motor will be shutdown.

The Supply Air Temperature (SAT) is controlled by staging compressors on and off to satisfy the "Operating Cooling Supply Air Temp Set point". There are 3 set points that determine the resulting "Operating Cooling Supply Air Temp Set point".

1. VAV Cooling Supply Air Temp Upper Set point (default 60° F)
2. VAV Cooling Supply Air Temp Lower Set point (default 55° F)
3. VAV Supply Air Temp Reset Set point (default 72° F)

When the Return Air Temp (RAT) is above the "VAV Supply Air Temp Reset Set point" the SAT will be maintained at +/- 5 degrees of the "VAV Cooling Supply Air Temp Lower Set point".



When the Return Air Temp (RAT) is below the "VAV Supply Air Temp Reset Set point" the SAT will be maintained at +/- 5 degrees of the "VAV Cooling Supply Air Temp Upper Set point".

When the Outdoor air condition is sufficient for free cooling, the economizer will modulate to control the SAT to +/- 1 degrees of the operational set point.

### Cooling Operation Errors

Each cooling system is monitored for operation outside of the intended parameters. Errors are handled as described below. All system errors override minimum run times for compressors.

**NOTE:** The following components are needed to access the control points in the Simplicity® SE control. Installation and operation guides are located on [www.upgnet.com](http://www.upgnet.com) under Product Center \ Equipment Catalog \ Commercial Products \ Zoning Systems and Controls.

1. Local LCD on Unit Control Board.  
OR
2. Mobile Access Portal (MAP) Gateway (Portable).
  - Source 1 P/N S1-JC-MAP1810-OP
3. MAP Gateway Quick Start Guide P/N 24-10737-16
4. MAP Gateway Instruction P/N 24-10737-8

### High-Pressure Limit Switch

During cooling operation, if a high-pressure limit switch opens, the UCB will de-energize the associated compressor, initiate the ASCD (Anti-short cycle delay), and, if the other compressor is idle, stop the condenser fans. If the call for cooling is still present at the conclusion of the ASCD, the UCB will re-energize the halted compressor.

Should a high-pressure switch open three times within two hours of operation, the UCB will lock-out the associated compressor. If the other compressor is inactive, the condenser fans will be de-energized.

### Low-Pressure Limit Switch

The low-pressure limit switch is not monitored during the initial 30 seconds of a cooling system's operation. For the following 30 seconds, the UCB will monitor the low-pressure switch to ensure it closes. If the low-pressure switch fails to close after the 30-second monitoring phase, the UCB will de-energize the associated compressor, initiate the ASCD, and, if the other compressor is idle, stop the condenser fans. If the LPS is still open after the ASCD, the compressor will not be energized for 30 seconds. The second and third times that the UCB sees an open LPS will count towards the three occurrences that will cause a UCB lock-out.

Once the low-pressure switch has been proven (closed during the 30-second monitor period described above), the UCB will monitor the low-pressure limit switch for any openings. If the low-pressure switch opens for greater than 5 seconds, the UCB

will de-energize the associated compressor, initiate the ASCD, and, if the other compressor is idle, stop the condenser fans.

If the call for cooling is still present at the conclusion of the ASCD, the UCB will re-energize the halted compressor.

Should a low-pressure switch open three times within one hour of operation, the UCB will lock-out the associated compressor. If the other compressor is inactive, the condenser fans will be de-energized.

### Evaporator Low Limit

During cooling operation, if the **Evaporator Low Limit Sensor (EC1, 2, 3, 4)** (Located on the Suction Line at the Evaporator Coil.) detects a temperature below 26 Deg. F (default), the UCB will de-energize the associated compressor, initiate the ASCD, and, if the other compressor is idle, stop the condenser fans. If the call for cooling is still present at the conclusion of the ASCD, the UCB will re-energize the halted compressor. Should the UCB detect the evaporator low limit sensor (**EC1, 2, 3, 4**) falling below 26 Deg. F (default) three times within two hours of operation, the UCB will lock-out the associated compressor. If the other compressor is inactive, the condenser fans will be de-energized.

### Low Ambient Cooling

To determine when to operate in low ambient mode, the UCB has an **Outdoor Air Temperature Sensor (OAT)** with a low ambient setpoint at 45°F (default). When the **OAT Sensor** senses a temperature below the low ambient setpoint and the thermostat is calling for cooling, the UCB will operate in the low ambient mode.

Low ambient mode operates the compressors in this manner: 10 minutes on, 5 minutes off. The indoor blower is operated throughout the cycle. The 5-minute off period is necessary to defrost the indoor coil.

Low ambient mode always begins with compressor operation. Compressor minimum run time may extend the minutes of compressor operation. The off cycle will begin immediately following the elapse of the minimum run time.

When operating in low ambient mode, an evaporator low limit sensor (**EC1, 2, 3, 4**) temperature below 26°F will de-energize the associated compressor. If the call for cooling is still present at the end of the ASCD and the evaporator temperature sensor (**EC1, 2, 3, 4**) temperature is above 26°F, the unit will resume operation.

### Safety Controls

The unit control board monitors the following inputs for each cooling system:

1. An evaporator low limit sensor (**EC1, 2, 3, 4**) (Located on the Suction Line at the Evaporator Coil.) to protect against low evaporator temperatures due to a low airflow or a low return air temperature, set at 26°F.
2. A high-pressure switch to protect against excessive discharge pressures due to a blocked condenser coil or a

condenser motor failure, (opens at  $625 \pm 25$  psig and resets  $500 \pm 25$  psig).

3. A low-pressure switch to protect against loss of refrigerant charge, (opens at  $50 \pm 5$  psig and resets at  $71 \pm 5$  psig).

The above pressure switches are hard-soldered to the unit. The refrigeration systems are independently monitored and controlled. On any fault, only the associated system will be affected by any safety/preventive action. The other refrigerant system will continue in operation unless it is affected by the fault as well.

The unit control board monitors the temperature limit switch of electric heat units and the temperature limit switch and the gas valve of gas furnace units.

### Compressor Protection

In addition to the external pressure switches, the compressors also have inherent (internal) protection. If there is an abnormal temperature rise in a compressor, the protector will open to shut down the compressor. The UCB incorporates features to minimize compressor wear and damage. An **Anti-Short Cycle Delay (ASCD)** is utilized to prevent operation of a compressor too soon after its previous run. Additionally, a minimum run time is imposed any time a compressor is energized.

The ASCD is initiated on unit start-up and on any compressor reset or lock-out.

### Reset

Remove the call for cooling, by raising thermostat setting higher than the conditioned space temperature.

### Electric Heating Sequence Of Operations

The following sequence describes the operation of the electric heat section.

## ⚠ CAUTION

For units with VFD and electric heat, the speed of the indoor blower motor continues to be controlled by duct static pressure via the Simplicity SE control board.

If there are VAV boxes present in the duct system, the boxes must be driven to the full-open position using a customer-supplied power source to assure adequate airflow across the heating elements.

Single-stage heating: (applies only to 18 KW heater, all other heaters MUST use a two-stage thermostat)

- a. Upon a call for heat by the thermostat, the heater contactor (6M) will be energized. After completing the specified fan on delay for heating, the UCB will energize the blower motor.

- b. The thermostat will cycle the electric heat to satisfy the heating requirements of the conditioned space.

Two-stage heating: (applies to all heaters except 18 KW)

- a. Upon a call for first-stage heat by the thermostat, the heater contactor (6M) (6M & 7M on 72 KW, 240V) will be energized. After completing the specified fan on delay for heating, the UCB will energize the blower motor.

If the second stage of heat is required, heater contactor (7M) will be energized. Note that on the 54 KW, 240V heater, heater contactors (7M & 8M) will be energized and on the 72 KW, 240V heater, heater contactors (8M & 9M) will be energized. After completing the specified fan on delay for heating, the UCB will energize the blower motor.

- b. The thermostat will cycle the electric heat to satisfy the heating requirements of the conditioned space.

**NOTE:** All 240 & 480V heaters are provided with manual reset backup protection limits. These will de-energize the heaters should the primary limit fail to open or the contactors fail to open in a failure mode.

### Electric Heat Operation Errors

#### Temperature Limit

If the UCB senses zero volts from the high temperature limit, the indoor blower motor is immediately energized.

This limit is monitored regardless of unit operation status, i.e. the limit is monitored at all times.

If the temperature limit opens three times within one hour, it will lock-on the indoor blower motor.

#### Safety Controls

The UCB monitors the temperature limit switch of electric heat units.

The control circuit includes the following safety controls:

#### Temperature Limit Switch (TLS)

1. Temperature Limit Switch (TLS 1, 2).

This control is located inside the heater compartment and is set to open at the temperature indicated in the Limit Control Setting Table 21. It resets automatically. The limit switch operates when a high temperature condition, caused by inadequate supply air flow occurs, thus shutting down the heater and energizing the blower.

2. Temperature Limit Switch (TLS 3, 4, 5 and 6).

This control is located inside the heater compartment and is set to open at the temperature indicated in the Limit Control Setting Table 21. It is a manual reset limit. These limit switches will de-energize the heaters should the primary limit fail to open or the contactors fail to open in a failure mode.

**Table 21: Limit Control Setting**

Unit (Tons)	Voltage	Heater Kw	Temperature, Limit Switch 1, 2 Opens, °F	Temperature, Limit Switch 3, 4, 5, 6 Opens, °F
15	240	18	120	170
		36	120	170
		54	120	170
		72	120	170
17.5, 20 and 25	240	18	140	200
		36	140	200
		54	140	200
		72	140	200
15, 17.5, 20 and 25	460	18	120	170
		36	120	170
		54	120	170
		72	120	170
15, 17.5, 20 and 25	600	18	120	-
		36	120	-
		54	120	-
		72	120	-

**Reset**

Remove the call for heating by lowering the thermostat setting lower than the conditioned space temperature.

**Electric Heat Anticipator Setpoints**

It is important that the anticipator setpoint be correct. Too high of a setting will result in longer heat cycles and a greater temperature swing in the conditioned space. Reducing the value below the correct setpoint will give shorter "ON" cycles and may result in the lowering of the temperature within the conditioned space. Refer to Table 22 for the required electric heat anticipator setting.

**Table 22: Electric Heat Anticipator Setpoint**

Heater Kw	Voltage	Setting, Amps	
		Th1	Th2
18	208/230-3-60	0.29	-
36		0.29	0.29
54		0.29	0.58
72		0.29	0.58
18	460-3-60	0.29	-
36		0.29	0.29
54		0.29	0.29
72		0.29	0.29
18	575-3-60	0.29	-
36		0.29	0.29
54		0.29	0.29
72		0.29	0.29

**Gas Heating Sequence Of Operations**

The following sequence describes the operation of the gas heat section.

**CAUTION**

For units with VFD and gas heat, the speed of the indoor blower motor continues to be controlled by duct static pressure via the VAV control board.

If there are VAV boxes present in the duct system, the boxes must be driven to the full-open position using a customer-supplied power source to assure adequate airflow across the heat exchanger tubes.

When the thermostat calls for the first stage of heating, the low-voltage control circuit from "R" to "W1" and "G" is completed, thru the UCB. The heat relay "RW1" is energized. The "RW1-2" contacts close energizing the draft motor control. The draft motor control contacts close and start the draft motor. As the speed of the draft motor reaches approximately 2500 RPM, the centrifugal switch contact, located on the end of the draft motor shaft, closes to power the first stage ignition module "IC1", thru the "RW1-1" contacts.

Ignition module "IC1" will immediately start the first stage igniter sparking and will open the redundant valve located inside the first stage main gas valve "GV1" to allow a flow of gas to only the first stage carryover tube. Only after the pilot flame has been ignited and the presence of pilot flame detected at the "IC1" by a signal sent back through the flame sensor is sparking terminated and the first stage main gas valve opened.

Gas flows into each of the main burners and is ignited from the carryover tube flame.

After completing the specified fan on delay for heating, the UCB will energize the blower motor.

If "IC1" fails to detect a pilot flame, it will continue to try for a maximum of 85 seconds to ignite the pilot tube. If the pilot flame is not detected, then "IC1" will lock out first stage furnace operation for five minutes or until 24V power is removed from the module either at the unit or by resetting the room thermostat.

When the thermostat calls for the second stage of heating, the low-voltage control circuit from "R" to "W2" is completed, thru the UCB. Heat relay "RW2" is energized. The "RW2-1" contact is closed energizing the second stage ignition module "IC2". "IC2" will immediately start the second stage igniter sparking and will open the redundant valve located inside the second stage main gas valve "GV2" to allow a flow of gas to the second stage carryover tube. Only after the pilot flame has been ignited and the presence of pilot flame detected at "IC2" by a signal sent back through the flame sensor is sparking terminated and the main gas valve opened.

Gas flows into each of the second stage main burners and is ignited from the carryover tube flame.

If "IC2" fails to detect a pilot flame, it will continue to try for a maximum of 85 seconds to ignite the pilot tube. If the pilot flame is not detected, then "IC2" will lock out first stage furnace operation for five minutes or until 24V power is removed from

the module either at the unit or by resetting the room thermostat.

**NOTE:** That the second stage furnace can operate even if first stage has locked out.

When the thermostat satisfies de-energizing the “RW2” and “RW1”, thus opening all gas valves. The blower motor will continue to run after the furnace is shut down until the specified fan off delay for heating has been satisfied. The UCB will de-energize the blower motor.

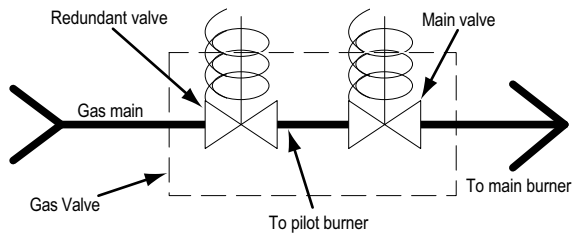

**Figure 20: Gas Valve Piping**

When the thermostat calls for the first stage of heating, the low-voltage control circuit from “R” to “W1” is completed. A call for heat passes through the UCB to the ignition control board (ICB). The UCB monitors the “W1” call and acts upon any call for heat. Once voltage has been sensed at “W1”, the UCB will initiate the fan on delay for heating, energizing the indoor blower after the specified delay has elapsed.

When the thermostat has been satisfied, heating calls are ceased. The GV is immediately de-energized. The blower is de-energized after the fan off delay for heating has elapsed. The draft motor performs a 25-second post purge.

## Gas Heating Operation Errors

### Temperature Limit

If the UCB senses zero volts from the high temperature limit, the indoor blower motor is immediately energized. When the UCB again senses 24 volts from the temperature limit, the draft motor will perform a 25-second post-purge and the indoor blower will be de-energized following the elapse of the fan off delay for heating.

This limit is monitored regardless of unit operation status, i.e. this limit is monitored at all times.

If the temperature limit opens three times within one hour, it will lock-on the indoor blower motor.

### Gas Valve

The UCB continuously monitors the GV. Any time the UCB senses voltage at the GV without a call for heat for a continuous five-minute period, the UCB will lock-on the indoor blower. When voltage is no longer sensed at the GV, the UCB will de-energize the indoor blower following the elapse of the fan off delay for heating.

If voltage has been sensed at the GV for at least 15 seconds during the fan on delay for heating and GV voltage or “W1” is lost, the indoor blower is forced on for the length of the fan off delay for heating.

## Safety Controls

The UCB monitors the temperature limit switch of gas heat units.

The control circuit includes the following safety controls:

### Limit Switch (LS)

This control is located inside the gas heat compartment and is set to open at the temperature indicated in the Gas Heat Limit Control Settings Table 23. It resets automatically. The limit switch operates when a high temperature condition, caused by inadequate supply air flow occurs, thus shutting down the heater and energizing the blower.

### Centrifugal Switch (CS)

If the draft motor should fail, the centrifugal switch attached to the shaft of the motor prevents the ignition controls and gas valves from being energized.

### Redundant Gas Valve

There are two separate gas valves in the furnace. Each valve contains a main and a redundant valve. The redundant valves are located upstream of the main gas valves. Should either or both of the main gas valves fail in the open position the redundant valves serve as back-ups and shut off the flow of gas.

### Flame Sensor Rod / 100% Ignition Control Lock-Out.

The flame rods and controls are located per Proper Flame Adjustment Figure 22. If an ignition control fails to detect a signal from the flame sensor indicating the pilot flame is properly ignited, then the main gas valve will not open. It will continue to try and ignite the pilot for a maximum of 85 seconds, then if the pilot flame is not detected, the ignition control will lock out furnace operation until 24V power is removed from the module either at the unit or by resetting the room thermostat.

### Rollout Switch

This switch is located above the main burners in the control compartment, which in the event of a sustained main burner rollout shuts off and locks out both ignition controls closing both gas valves. The ignition controls lock out furnace operation until 24V power is removed from the controls either at the unit or by resetting the room thermostat.

### Auxiliary Limit Switch (AUX)

This control is located inside the heat exchanger compartment and is set to open at 190°F. It is a manual reset switch. If AUX trips, then the primary limit has not functioned correctly. Replace the primary limit.

**Table 23: Gas Heat Limit Control Setting**

Units (Tons)	Capacity, MBH		Limit Control Opens, °F
	Input	Output	
15, 17.5, 20 & 25	300	240	195
15, 17.5, 20 & 25	400	320	195

The ICB monitors the Pressure and Rollout switches of gas heat units.

The control circuit includes the following safety controls:

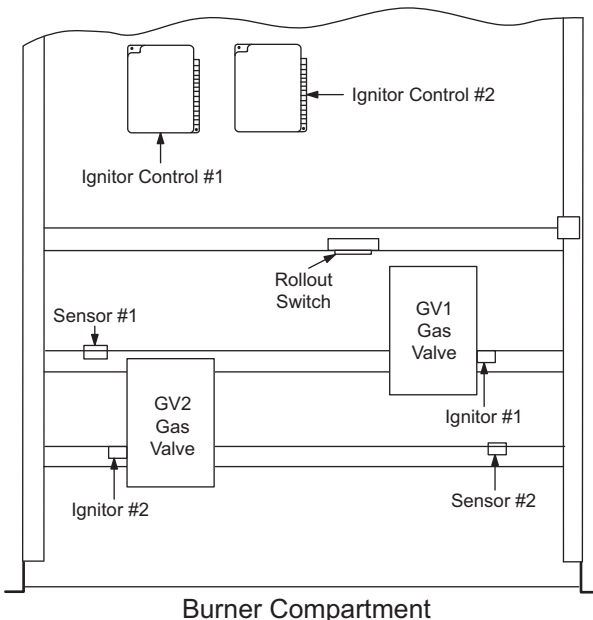
**Figure 21: Gas Valve and Controls**

### Resets

Remove the call for heating by lowering the thermostat setting lower than the conditioned space temperature.

### Gas Heat Anticipator Setpoints

It is important that the anticipator setpoint be correct. Too high of a setting will result in longer heat cycles and a greater temperature swing in the conditioned space. Reducing the value below the correct setpoint will give shorter "ON cycles and may result in the lowering of the temperature within the conditioned space. Refer to Table 24 for the required gas heat anticipator setting.

**Table 24: Gas Heat Anticipator Setpoints**

Gas Valve	Anticipator Setpoint	
	1st Stage	2nd Stage
Honeywell VR8440	0.30 amp	0.11 amp
White-Rodgers 36C68		

## Start-Up (Cooling)

### Prestart Check List

After installation has been completed:

1. Check the electrical supply voltage being supplied. Be sure that it is the same as listed on the unit nameplate.
2. Set the room thermostat to the off position.
3. Turn unit electrical power on.
4. Set the room thermostat fan switch to on.
5. Check indoor blower rotation.
  - If blower rotation is in the wrong direction. Refer to Phasing Section in general information section.
 Check blower drive belt tension.
6. Check the unit supply air (CFM).
7. Measure evaporator fan motor's amp draw.
8. Set the room thermostat fan switch to off.
9. Turn unit electrical power off.

### Operating Instructions

1. Turn unit electrical power on.
2. Set the room thermostat setting to lower than the room temperature.
3. First stage compressors will energize after the built-in time delay (five minutes).
4. The second stage of the thermostat will energize second stage compressor if needed.

### Post Start Check List

1. Verify proper system pressures for both circuits.
2. Measure the temperature drop across the evaporator coil.
3. Measure the system amperage draw across all legs of 3 phase power wires.
4. Measure the condenser fan amperage draw.

## Start-Up (Gas Heat)

### Pre-Start Check List

Complete the following checks before starting the unit.

1. Check the type of gas being supplied. Be sure that it is the same as listed on the unit nameplate.
2. Make sure that the vent and combustion hoods have been properly installed.

## Operating Instructions

### CAUTION

This furnace is equipped with an intermittent pilot and automatic re-ignition system. DO NOT attempt to manually light the pilot.

### Lighting The Main Burners

1. Turn "OFF" electric power to unit.
2. Turn room thermostat to lowest setting.
3. Turn gas valve knob or switch to "ON" position (See Figure 24).
4. Turn "ON" electric power to unit.
5. Set room thermostat to desired temperature (If thermostat "set" temperature is above room temperature, pilot burner ignition will occur and, after an interval to prove pilot flame, main burners will ignite).

### Post Start Checklist

After the entire control circuit has been energized and the heating section is operating, make the following checks:

1. Check for gas leaks in the unit piping as well as the supply piping.

### WARNING

#### FIRE OR EXPLOSION HAZARD

Failure to follow the safety warning exactly could result in serious injury, death or property damage.

Never test for gas leaks with an open flame. Use a commercially available soap solution made specifically for the detection of leaks to check all connections. A fire or explosion may result causing property damage, personal injury or loss of life.

2. Check for correct manifold gas pressures. (See CHECKING GAS INPUT.)
3. Check the supply gas pressure. It must be within the limits shown on the rating nameplate. Supply pressure should be checked with all gas appliances in the building at full fire. At no time should the standby gas pressure exceed 13 in. or the operating pressure drop below 5.0 in. for natural gas units. If gas pressure is outside these limits, contact the local gas utility or propane supplier for corrective action.

### Shut Down

1. Set the thermostat to the lowest temperature setting.
2. Turn "OFF" all electric power to unit.
3. Open gas heat access panel.
4. Turn gas valve clockwise to "OFF" position (See Figure 24).

## Checking Gas Heat Input

1. Turn off all other gas appliances connected to the gas meter.
2. With the furnace turned on, measure the time needed for one revolution of the hand on the smallest dial on the meter. A typical gas meter usually has a 1/2 or a 1 cubic foot test dial.
3. Using the number of seconds for each revolution and the size of the test dial increment, find the cubic feet of gas consumed per hour from the Gas Rate - Cubic Feet Per Hour Table 25.

If the actual input is not within 5% of the furnace rating (with allowance being made for the permissible range of the regulator setting), replace the orifice spuds with spuds of the proper size.

**NOTE:** To find the Btu input, multiply the number of cubic feet of gas consumed per hour by the Btu content of the gas in your particular locality (contact your gas company for this information - it varies widely from city to city.).

**Table 25: Gas Rate Cubic Feet Per Hour**

Seconds for One Rev.	Size of Test Dial	
	1/2 cu. ft.	1 cu. ft.
4	450	900
6	300	600
8	228	450
10	180	360
12	150	300
14	129	257
16	113	225
18	100	200
20	90	180
22	82	164
24	75	150
26	69	138
28	64	129

### EXAMPLE

By actual measurement, it takes 13 seconds for the hand on the 1-cubic foot dial to make a revolution with just a 300,000 Btuh furnace running. Read across to the column in the table above, headed "1 Cubic Foot", where you will see that 278 cubic feet of gas per hour are consumed by the furnace at that rate. Multiply 278 x 1050 (the Btu rating of the gas obtained from the local gas company). The result is 292,425 Btuh, which is close to the 300,000 Btuh rating of the furnace.

### Manifold Gas Pressure Adjustment

Small adjustments to the high-fire gas flow may be made by turning the pressure regulator adjusting screw on the automatic gas valve.

Adjust as follows:

1. Remove the cap on the regulator. It's located next to the push-on electrical terminals.

- To decrease the gas pressure, turn the adjusting screw counterclockwise.
- To increase the gas pressure, turn the adjusting screw clockwise.

**NOTE:** The correct manifold pressure for these furnaces is 3.65 IWG  $\pm$  0.3.

### Adjustment Of Temperature Rise

The temperature rise (the difference of temperature between the return air and the heated air from the furnace) must lie within the range shown on the CSA rating plate and the data in Table 11.

After the temperature rise has been determined, the CFM can be calculated as follows:

$$\text{CFM} = \text{Btu Input} \cdot \frac{0.8}{(1.08 \cdot \Delta^{\circ}\text{F})}$$

After about 20 minutes of operation, determine the furnace temperature rise. Take readings of both the return air and the heated air in the ducts (about 6 feet from the furnace) where they will not be affected by radiant heat. Increase the blower CFM to decrease the temperature rise; decrease the blower CFM to increase the rise (See SUPPLY AIR DRIVE ADJUSTMENT).

**NOTE:** Each gas heat exchanger size has a minimum allowable CFM. Below this CFM, the limit will open.

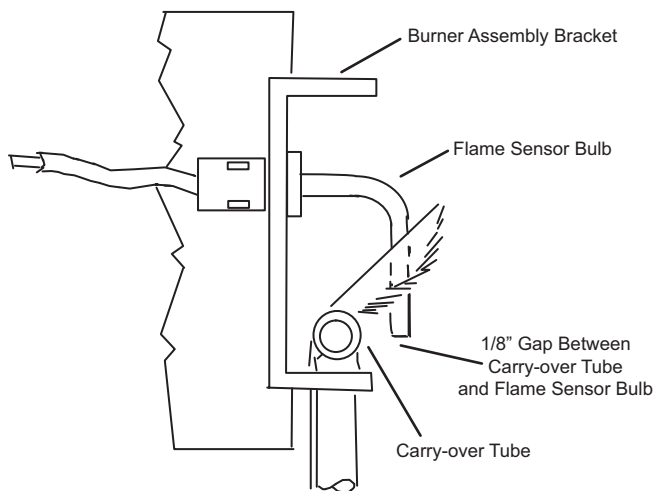

**Figure 22: Proper Pilot Flame Adjustment**

### Pilot Checkout

The pilot flame should envelope the end of the flame sensor. To adjust pilot flame, (1) remove pilot adjustment cover screw, (2) increase or decrease the clearance for air to the desired level, (3) be sure to replace cover screw after adjustment to prevent possible gas leakage.

Put the system into operation and observe through complete cycle to be sure all controls function properly.

### Burner Instruction

To check or change burners, pilot or orifices, CLOSE MAIN MANUAL SHUT-OFF VALVE AND SHUT OFF ALL ELECTRIC POWER TO THE UNIT.

- Remove the screws holding either end of the manifold to the burner supports.
- Open the union fitting in the gas supply line just upstream of the unit gas valve and downstream from the main manual shut-off valve.
- Remove the gas piping closure panel.
- Disconnect wiring to the gas valves and spark ignitors. Remove the manifold-burner gas valve assembly by lifting up and pulling back.

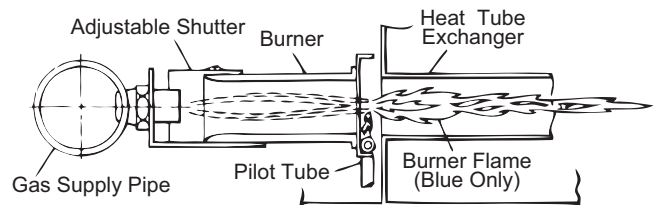

**Figure 23: Typical Flame**

Burners are now accessible for service.

Reverse the above procedure to replace the assemblies. Make sure that burners are level and seat at the rear of the heat exchanger.

### Burner Air Shutter Adjustment

Adjust burner shutters so no yellow flame is observed in the heat exchanger tubes.

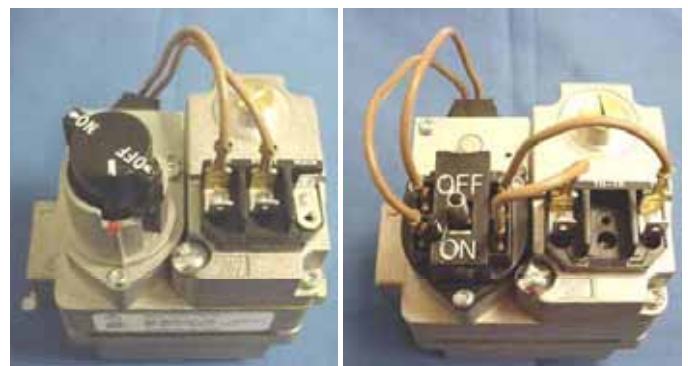

**Figure 24: Typical Gas Valve**

## Charging The Unit

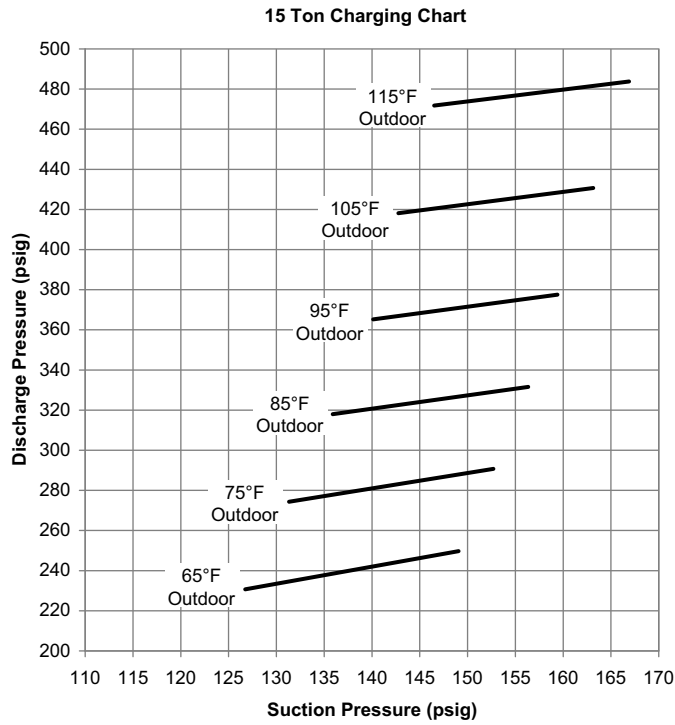

Figure 25: ZJ180 (15 Ton) Charging Chart

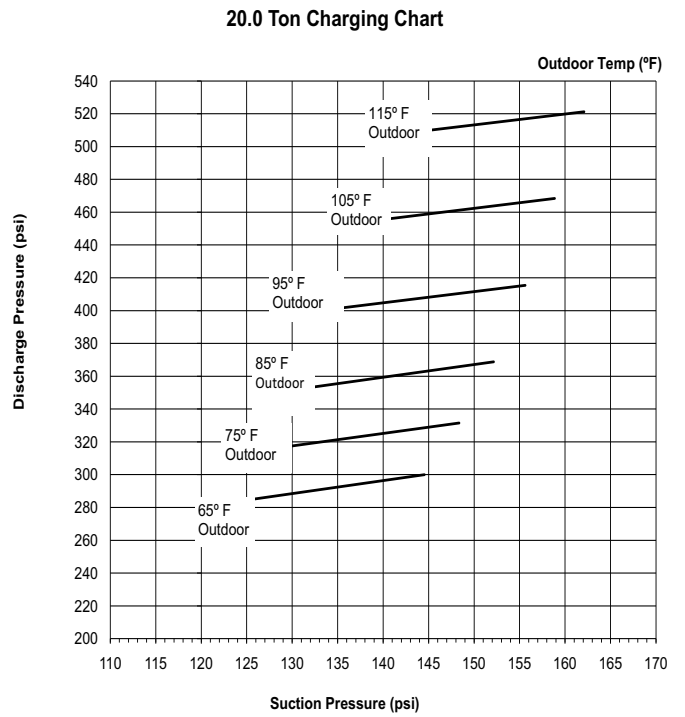

Figure 27: ZJ240 (20 Ton) Charging Chart

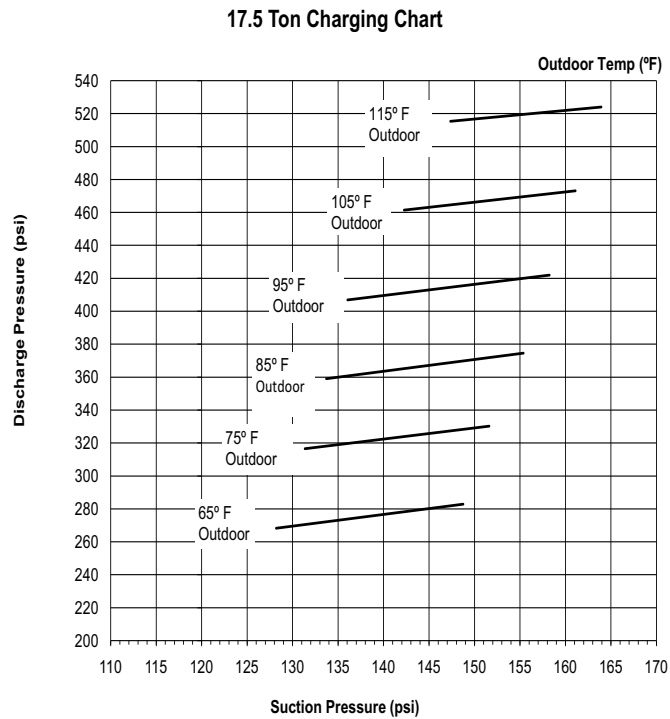

Figure 26: ZJ210 (17.5 Ton) Charging Chart

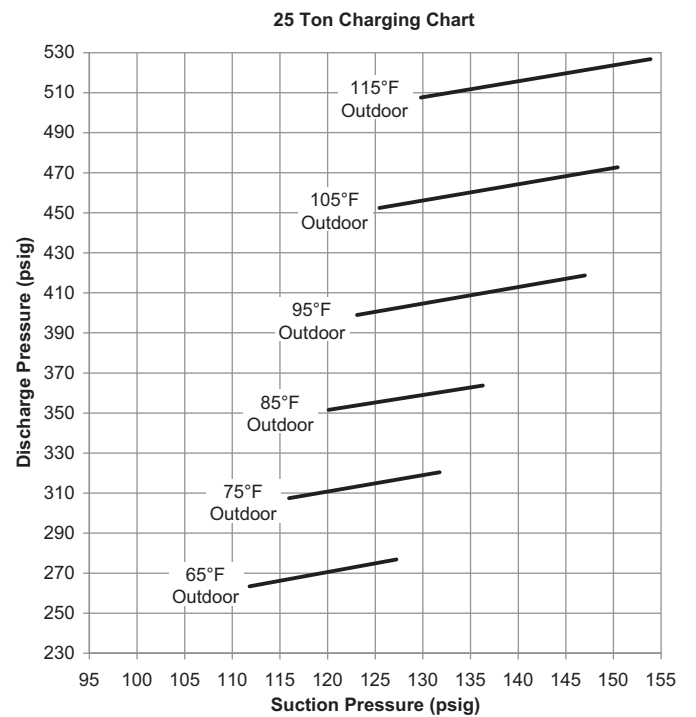

Figure 28: ZJ300 (25 Ton) Charging Chart



## SIMPLICITY™ SE (SMART EQUIPMENT) FIRMWARE VERSION 3. BASIC UNIT CONTROL BOARD NAVIGATION EXAMPLES:

The following document details the navigation and viewing of the LCD display screen equipped as a standard item on the Simplicity SE control installed within various commercial UPG packaged and split system equipment. The following information provides a step-by-step demonstration on how to

navigate the basic status menu and how to change basic configuration settings. The basic navigation steps outlined in this short demonstration applies to most menus within the Simplicity SE control.



### Understanding the Local LCD

After you apply power to your Rooftop Unit (RTU), a start-up countdown begins on the Unit Control Board (UCB) LCD. When the controller is ready, the screen is blank because no faults are present. Use the joystick and the two push buttons below the LCD, to navigate through the menus.

**Step 1** - After the start-up countdown is complete the first screen displayed is the "Status & Alarms" screen. When the cursor is on the top "Status" line hit the "ENTER" button. This action steps the LCD display into the status mode. Hit "ENTER" to view the status menu.

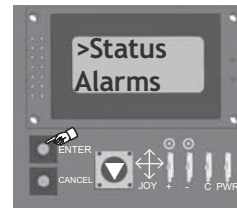

**Step 2** - The first item under the status menu is "DVent-Mode". This is the demand ventilation mode.

**Step 3** - When the cursor is on the "DVent-Mode" hit "ENTER" to view the status of this mode. In this case a CO2 sensor is not installed, thus Demand Ventilation or DVent is disabled.

**Step 4** - To exit out of the "DVent-Mode status screen push "Cancel". The screen returns to that shown below.

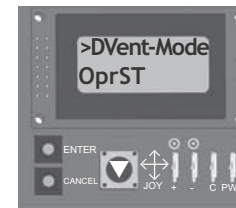
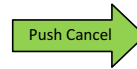
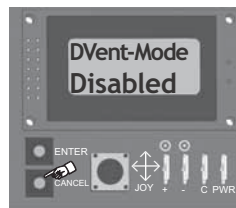
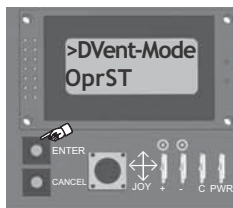

**Step 5** - By pushing the joystick down, the cursor toggles to OprST (Operating Space Temp).

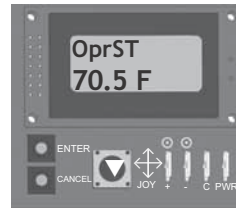
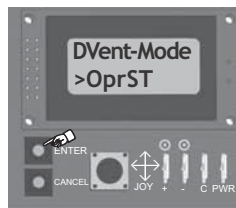

**Step 6** - By pushing "ENTER" the actual OprST (Operating Space Temp) appears. Pushing the joystick down scrolls through SAT, RAT, OAT and other available sensor readings.

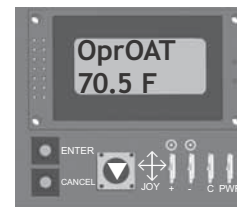
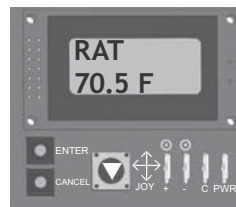
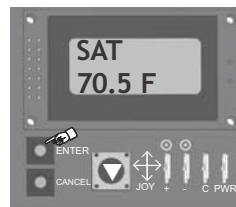

Press the "Cancel" button to exit each menu level. Repeatedly pressing "Cancel" returns the menu to the first "Status, Alarms" screen.

When the "Cancel" button is pressed multiple times to exit each menu level and the screen returns to the first "Status, Alarms" display the next demonstration can begin. In this demonstration the information below steps through the "Commissioning" menu.

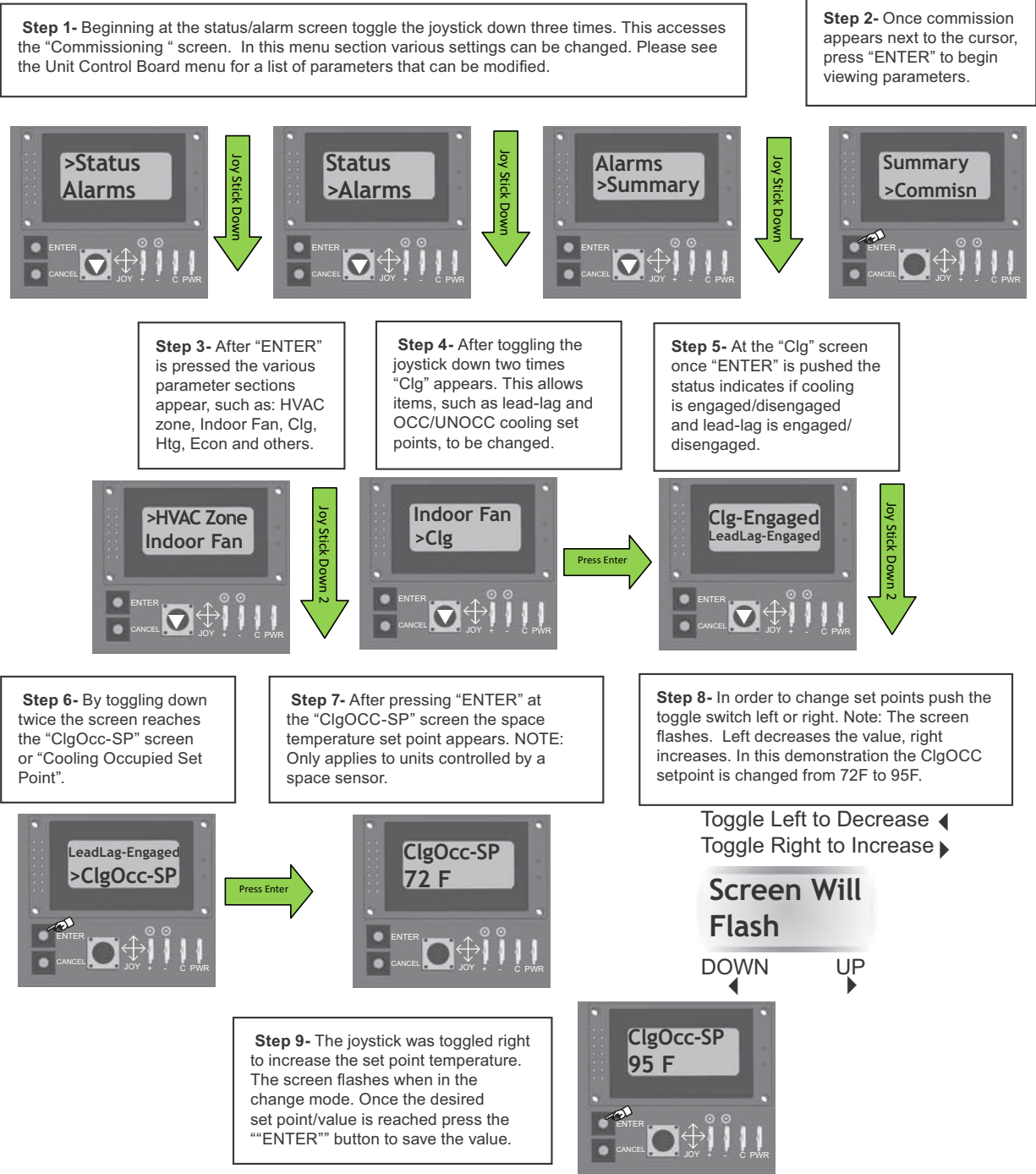

These few pages provide a simple demonstration how to navigate the menu's of the Simplicity SE control containing Version 3 firmware. Please utilize this document along with the additional information in the Users Guide and detailed navigation menu to adjust the control to customer preferences or job specifications.

**NOTE: IF OPERATING THE EQUIPMENT WITH A THERMOSTAT, THE UCB SETPOINTS AND PARAMETERS SHOULD NOT REQUIRE ALTERATION; HOWEVER, THERE MAY BE THE CASE WHERE MINIMUM OUTSIDE AIR, LEAD-LAG OR OTHER CUSTOM SETTINGS ARE REQUIRED. PLEASE READ THIS DOCUMENT IN DETAIL TO UNDERSTAND THE IMPLICATIONS OF MAKING CHANGES BEFORE PROCEEDING. IT IS STRONGLY RECOMMENDED THAT A BACKUP OF PARAMETER SETTINGS BE SAVED ON A USB DRIVE BEFORE MAKING ANY MAJOR CHANGES TO THE CONTROL!**



Figure 29: Unit Control Board

Table 26: Simplicity SE UCB Details

Description	Function & Comments
<b>Terminal Directional orientation: viewed with silkscreen labels upright</b>	
<b>Limit, 24 VAC power and shutdown connections from unit wiring harness at left on upper edge of UCB</b>	
<b>LIMIT</b>	Monitored 24 VAC input through heat section limit switch(es) If voltage is absent, indicating the heat section is over-temperature, the UCB will bring on the indoor blower
<b>C</b>	24 VAC, 75 VA transformer Common referenced to cabinet ground Connects through circuit traces to thermostat connection strip C and indoor blower VFD pin C
<b>24V</b>	24 VAC, 75 VA transformer hot Powers the UCB microprocessor, connects through circuit trace to the SD 24 terminal
<b>SD 24</b>	24 VAC hot out for factory accessory smoke detector, condensate overflow and/or user shutdown relay switching in series Connects through circuit trace to thermostat connection strip SD-24. A wiring harness jumper plug connecting SD 24 to SD R is in place if factory accessories for unit shutdown are not used - this jumper plug must be removed if the switching of field-added external accessories for unit shutdown are wired between thermostat connection strip SD-24 and R
<b>SD R</b>	24 VAC hot return from factory accessory smoke detector, condensate overflow and user shutdown relay switching in series Connects through circuit trace to the R terminal on the upper left of the board
<b>R</b>	24 VAC hot for switched inputs to the UCB Connects through circuit trace to the thermostat connection strip R terminal, right FAN OVR pin, right HPS1 pin, right HPS2 pin, lower DFS pin and lower APS pin

**Table 26: Simplicity SE UCB Details (Continued)**

Description		Function & Comments
<b>Terminal Thermostat connection strip on left edge of UCB</b>		
<b>W1</b>	1st stage heating request, 24 VAC input switched from R	Not effective for cooling-only units
<b>W2</b>	2nd stage heating request, 24 VAC input switched from R	Not effective for cooling-only units or units with single-stage heat sections
<b>Y1</b>	1st stage cooling request, 24 VAC input switched from R	
<b>Y2</b>	2nd stage cooling request, 24 VAC input switched from R	Visible in the display menu when the #ClgStgs parameter is set for 2 or more, also effective for economizer free cooling supply air temperature reset when the #ClgStgs parameter is set for 1 or more
<b>G</b>	Continuous indoor blower request, 24 VAC input switched from R	
<b>OCC</b>	Occupancy request, 24 VAC input switched from R	Must have the OccMode parameter set for External to be effective
<b>X</b>	Hard lockout indicator, 24 volt output to a light thermostat LED	
<b>R</b>	24 VAC hot for thermostat switching and power	If field-added external accessories for unit shutdown are used, 24 VAC hot return from smoke detector, condensate overflow and/or user shutdown relay switching in series
<b>SD-24</b>	If field-added external accessories for unit shutdown are used, 24 VAC hot out for smoke detector, condensate over- flow and/or user shutdown relay switching in series	Unit wiring harness jumper plug for factory shutdown accessories must be removed if the switching of field-added external accessories for unit shutdown are wired between thermo- stat connection strip SD-24 and R
<b>C</b>	24 VAC common for thermostat power	
<b>LEDs on left edge of UCB</b>		
<b>POWER</b>	Green UCB power indicator	Lit indicates 24 VAC is present at C and 24V terminals
<b>FAULT</b>	Red hard lockout, networking error and firmware error indicator	1/2 second on/off flashing indicates one or more alarm is currently active, 1/10th second on/off flashing indicates a networking error (polarity, addressing, etc.) or a firmware error (likely correctable with re-loading from USB flash drive)
<b>SA BUS</b>	Green UCB SA bus communication transmission indicator	Lit/flickering indicates UCB SA bus communication is currently active, off indicates the UCB is awaiting SA bus communication
<b>Terminal Space temperature sensor connections at center on upper edge of UCB</b>		
<b>ST</b>	Space Temperature sensor input from 10KΩ @ 77°F, Type III negative temperature coefficient thermistor	Positive of VDC circuit (3.625 VDC reading to COM with open circuit), effective if "Thermo- stat-only Control" parameter is set OFF, space sensor override momentary shorts ST to COM to initiate/terminate temporary occupancy
<b>COM</b>	Common for ST and SSO inputs	Negative of VDC circuit for ST and SSO inputs
<b>SSO</b>	Space Sensor Offset input from 0 to 20KΩ potentiometer	Positive of VDC circuit (3.625 VDC reading to COM with open circuit), 10KΩ/2.5 VDC is 0°F offset, 0Ω/0 VDC is maximum above offset and 20KΩ/3.4 VDC is maximum below offset from active space temperature setpoint
<b>Pin Temperature sensor connections at right on upper edge of UCB</b>		
<b>SAT+</b>	Supply Air Temperature sensor input from 10KΩ @ 77°F, Type III negative temperature coefficient thermistor	Input required for operation; 3.625 VDC reading SAT+ to SAT- with open circuit. Used in heat/cool staging cutouts, free cooling operation, demand ventilation operation, comfort ventilation operation, economizer loading operation, VAV cooling operation, hydronic heat operation.

Table 26: Simplicity SE UCB Details (Continued)

Description		Function & Comments
<b>RAT+</b>	Return Air Temperature sensor input from 10KΩ @ 77°F, Type III negative temperature coefficient thermistor	Input required for operation; 3.625 VDC reading RAT+ to RAT- with open circuit. Used in return air enthalpy calculation. Substitutes for space temperature if no other space temperature input is present.
<b>OAT+</b>	Outside Air Temperature sensor input from 10KΩ @ 77°F, Type III negative temperature coefficient thermistor	Input required for operation but may be a communicated value; 3.625 VDC reading OAT+ to OAT- with open circuit. Used in heat/cool cutouts, low ambient cooling determination, dry bulb free cooling changeover, outside air enthalpy calculation, economizer loading operation, heat pump demand defrost calculation.
<b>CC1+</b>	#1 refrigerant circuit Condenser Coil temperature sensor input from 10KΩ @ 77°F, Type III negative temperature coefficient thermistor	Input required for heat pump units, not required for A/C units; 3.625 VDC reading CC1+ to CC1- with open circuit. Used in heat pump demand defrost calculation.
<b>EC1+</b>	#1 refrigerant circuit Evaporator Coil temperature sensor input from 10KΩ @ 77°F, Type III negative temperature coefficient thermistor	Input required for operation; 3.625 VDC reading EC1+ to EC1- with open circuit. Used in suction line temperature safety.
<b>CC2+</b>	#2 refrigerant circuit Condenser Coil temperature sensor input from 10KΩ @ 77°F, Type III negative temperature coefficient thermistor	Input required for 2-compressor heat pump units, not required for 2-compressor A/C units, not active for 1-compressor units; 3.625 VDC reading CC2+ to CC2- with open circuit. Used in heat pump demand defrost calculation.
<b>EC2+</b>	#2 refrigerant circuit Evaporator Coil temperature sensor input from 10KΩ @ 77°F, Type III negative temperature coefficient thermistor	Input required for operation of 2-compressor units, not active for 1-compressor units; 3.625 VDC reading EC2+ to EC2- with open circuit. Used in suction line temperature safety.
<b>Pinned connections on right edge of UCB</b>		
<b>RAH+</b>	Return Air Humidity input from 0-10 VDC @ 0-100% RH sensor	Input required for reheat units, optional in all other units, may be a communicated value. Used in return air enthalpy calculation, temperature/humidity setpoint reset, reheat operation.
<b>DCT PRS+</b>	Supply Duct Pressure input from 0-5 VDC @ 0-5" w.c. sensor	Input required for variable air volume units. Used in VAV indoor blower operation.
<b>DFS (upper pin)</b>	24 VAC hot return from Dirty Filter Switch	Optional input; switch closure for greater than 15 seconds during indoor blower operation initiates a notification alarm
<b>DFS (lower pin)</b>	24 VAC hot out for Dirty Filter Switch	Connects through circuit trace to the R terminal
<b>APS (upper pin)</b>	24 VAC hot return from Air Proving Switch	When this optional input is enabled: the air proving switch must close within 30 seconds of initiation of indoor blower operation and not open for greater than 10 seconds during indoor blower operation to allow heat/cool operation and prevent an "APS open" alarm; the air proving switch must open within 30 seconds of termination of indoor blower operation to prevent an "APS stuck closed" notification alarm
<b>APS (lower pin)</b>	24 VAC hot out for Air Proving Switch	Connects through circuit trace to the R terminal
<b>C</b>	Common for the VFD output	Negative of the VDC circuit for the VFD output
<b>VFD</b>	2-10 VDC (0-100%) output for the indoor blower Variable Frequency Drive	Output is active with indoor blower operation. For CV units: this output provides stepped IntelliSpeed control of the indoor blower VFD based on fan-only, cooling stage and heating stage outputs. For VAV units: this output provides control of the indoor blower VFD based on supply duct static pressure input and setpoint.

**Table 26: Simplicity SE UCB Details (Continued)**

Description		Function & Comments
VFDFLT	24 VAC hot input from the normally open VFD alarm contact	The VFD alarm contact switches from R within the unit wiring harness. 24 VAC input results in unit shutdown and a "VFD fault" alarm
<b>Terminal at lower right corner of UCB</b>		
24V FOR OUTPUTS	24 VAC hot for H1, H2, CN-FAN, AUX HGR, FAN C1 and C2 output relay contact switching	Output relay circuitry is isolated from other UCB components and the 24 VAC hot source may be from a second transformer in the unit
<b>Pin Heat section connections at right on lower edge of UCB</b>		
H1	24 VAC hot output for heat section stage 1	Not effective for cooling-only units. Output if demand is present and permissions allow one stage or two stages of heat section operation
H2	24 VAC hot output for heat section stage 2	Not effective for cooling-only units or units with single-stage heat sections. Output if demand is present and permissions allow two stages of heat section operation
MV	24 VAC hot input confirming heat section operation	Sourced from gas valve in gas heat units or first stage heat contactor in electric heat units. Input within 5 minutes from initiation of H1 output initiates the "Heat On Fan Delay" timer, loss of input following the termination of H1 output initiates the "Heat On Fan Delay" timer, no input within 5 minutes from initiation of H1 output initiates an "Ignition Failure" alarm, input for longer than 5 minutes without H1 output initiates a "Gas Valve Mis-wire" alarm
<b>Pin Cooling and fan output connections at right on lower edge of UCB</b>		
CN-FAN	24 VAC hot output for the condenser fan contactor coil	Output with either C1 or C2 output; interrupted during defrost cycle for heat pump units
AUX HGR	24 VAC hot output for hot gas reheat components	Effective only for reheat units, output with reheat operation
FAN	24 VAC hot output for indoor blower contactor coil/indoor blower VFD enable relay coil	Output with heat/cool operation, G input or schedule demand
C1	24 VAC hot output for compressor 1	If demand is present and permissions allow compressor 1 operation; output with compressor cooling, comfort ventilation cooling, reheat or heat pump heating demands
C2	24 VAC hot output for compressor 2	Not effective for one stage compressor UCBs. If demand is present and permissions allow compressor 2 operation; output with compressor cooling, comfort ventilation cooling or heat pump heating demands
<b>Pin Refrigerant circuit safety switch and indoor blower overload connections at center on lower edge of UCB</b>		
HPS1 (right pin)	24 VAC hot out for refrigerant circuit 1 High Pressure Switch	Connects through circuit trace to the R terminal
HPS1 (left pin)	24 VAC hot return from refrigerant circuit 1 High Pressure Switch	Input is only considered if C1 output is needed; input must be present to allow C1 output. Three HPS1 trips in a two hour period cause a "High Pressure Switch 1 Lockout" and C1 output is then prevented until alarm reset. Connects through circuit trace to the right LPS1 pin.
LPS1 (right pin)	24 VAC hot out for refrigerant circuit 1 Low Pressure Switch	Connects through circuit trace to the left HSP1 pin
LPS1 (left pin)	24 VAC hot return from refrigerant circuit 1 Low Pressure Switch	Input is only considered after 30 seconds of C1 output; afterwards, input must be present to allow C1 output. Three LPS1 trips in a one hour period cause a "Low Pressure Switch 1 Lockout" and C1 output is then prevented until alarm reset.
HPS2 (right pin)	24 VAC hot out for refrigerant circuit 2 High Pressure Switch	Not effective for one stage compressor UCBs. Connects through circuit trace to the R terminal

Table 26: Simplicity SE UCB Details (Continued)

Description		Function & Comments
<b>HPS2 (left pin)</b>	24 VAC hot return from refrigerant circuit 2 High Pressure Switch	Not effective for one stage compressor UCBs. Input is only considered if C2 output is needed; input must be present to allow C1 output. Three HPS2 trips in a two hour period cause a "High Pressure Switch 1 Lockout" and C2 output is then prevented until alarm reset. Connects through circuit trace to the right LPS2 pin.
<b>LPS2 (right pin)</b>	24 VAC hot out for refrigerant circuit 2 Low Pressure Switch	Not effective for one stage compressor UCBs. Connects through circuit trace to the left HSP2 pin
<b>LPS2 (left pin)</b>	24 VAC hot return from refrigerant circuit 2 Low Pressure Switch	Not effective for one stage compressor UCBs. Input is only considered after 30 seconds of C2 output; afterwards, input must be present to allow C2 output. Three LPS2 trips in a one hour period cause a "Low Pressure Switch 2 Lockout" and C2 output is then prevented until alarm reset.
<b>FAN OVR (right pin)</b>	24 VAC hot out for indoor blower FAN Overload relay contact/motor protector switch	Connects through circuit trace to the R terminal
<b>FAN OVR (left pin)</b>	24 VAC hot return from indoor blower FAN Overload relay contact/motor protector switch	Input is only considered if FAN output is needed; input must be present to allow FAN output and unit operation. One FAN OVR trip lasting longer than 5 minutes or three FAN OVR trips in a two hour period cause a "Fan Overload Lockout" and unit operation is then prevented until alarm reset.
<b>Terminal SA BUS connections on at left on lower edge and center of UCB</b>		
<b>PWR</b>	Power for SA ("Sensor-Actuator") BUS devices	Also incorporated in the J8 6-pin phone jack connector at the left-center of the board. Positive of the 15 VDC (reading to C) circuit for powering an optional netstat and/or Multi Touch gateway
<b>C</b>	Common for SA BUS power and communication circuits	Also incorporated in the J8 6-pin phone jack connector at the left-center of the board. Negative of the SA BUS circuits
<b>-</b>	Communication for SA BUS devices	Also incorporated in the J8 6-pin phone jack connector at the left-center of the board. Positive of the VDC (typically, a fluctuating 1.5 to 3.5 volts reading to C; at least 0.25 volts lower than +) SA BUS communication circuit to optional economizer board, 4-stage board, fault detection & diagnostics board, netstat and/or Multi Touch gateway
<b>+</b>	Communication for SA BUS devices	Also incorporated in the J8 6-pin phone jack connector at the left-center of the board. Positive of the VDC (typically, a fluctuating 1.5 to 3.5 volts reading to C; at least 0.25 volts higher than -) SA BUS communication circuit to optional economizer board, 4-stage board, fault detection & diagnostics board, netstat and/or Multi Touch gateway
<b>J8</b>	6-pin phone jack connector	Incorporates the SA BUS terminals for convenience/alternate connection of SA BUS devices, primarily used for temporary service connection of the Multi Touch gateway
<b>Item Integrated user interface at lower left corner of UCB</b>		
<b>Display</b>	On-board, 2-line x 8-character back-lit display	On-board display, buttons and joystick allow access to UCB, economizer, 4-stage and FDD board parameters
<b>ENTER</b>	Button for display menu acknowledgment and navigation	
<b>CANCEL</b>	Button for display menu navigation and zeroing of active compressor ASCD timer	
<b>JOY</b>	4-way Joystick for display menu navigation	
<b>Item USB connector at right of UCB</b>		
<b>J10</b>	Type A female Universal Serial Bus connector	Used for backup, restoration, & copying of board parameters as well as board software updating through a flash drive

**Table 26: Simplicity SE UCB Details (Continued)**

Description		Function & Comments
<b>J15</b>	Factory wired SA Bus connector	
<b>Optional communication sub-board at center of UCB</b>		
<b>Terminal FC BUS connections on left edge of the communication board</b>		
<b>FC+</b>	FC ("Field Connected") BUS BACnet MSTP communication	Positive of the VDC (typically, a fluctuating 1.5 to 3.5 volts reading to COM; at least 0.25 volts higher than -) FC bus BACnet MSTP communication circuit
<b>FC-</b>	FC ("Field Connected") BUS BACnet MSTP communication	Positive of the VDC (typically, a fluctuating 1.5 to 3.5 volts reading to COM; at least 0.25 volts lower than +) FC bus BACnet MSTP communication circuit
<b>COM</b>	Common for the FC ("Field Connected") BUS BACnet MSTP communication circuit	Negative of the VDC FC bus BACnet MSTP communication circuit
<b>SHLD</b>	Shield for the FC ("Field Connected") BUS BACnet MSTP communication circuit	Earth ground reference of the cable to prevent interference on the FC bus BACnet MSTP communication circuit
<b>Item Selector in red housing at left on top edge of the communication board</b>		
<b>EOL switch</b>	End Of Line selector switch for the FC BUS BACnet MSTP communication circuit	ON selected only for the UCB that is the terminus of the FC bus BACnet MSTP communication cable to prevent signal "bounce-back"
<b>LEDs on the communication board</b>		
<b>EOL</b>	Green End Of Line indicator	Lit indicates the EOL switch is selected ON
<b>FC BUS</b>	Green FC bus communication transmission indicator	Lit/flickering indicates outgoing UCB FC bus communication is currently active, off indicates the UCB is awaiting incoming FC bus communication
<b>ISO PWR</b>	Green communication board Isolated Power indicator	Lit indicates the UCB is supplying power to the communication sub-board





Figure 30: 4-Stage Board

Table 27: 4-Stage Board

Terminal	Description	Function and Comments
<b>Directional Orientation : Viewed with silkscreen labels upright</b>		
<b>C and R Terminals at left on upper edge of 4-Stage Board</b>		
C	24VAC common for 4-stage board power	
R	24VAC hot for 4-stage board power	
<b>Communication Terminals</b>		
PWR	Sensor Actuator (SA) Bus Power for SA bus devices	Not used on 4-stage board
COM	Common for SA BUS power and communication circuits	Negative of the SA BUS circuits
SA-	Communication for SA BUS devices	<b>Negative</b> of the VDC (typically, a fluctuating 1.5 to 3.5 volts reading to C; at least 0.25 volts lower than +) SA BUS communication circuit to optional economizer board, 4-stage board, fault detection & diagnostics board, netstat and/or <b>MAP-Gateway</b>
SA+	Communication for SA BUS devices	<b>Positive</b> of the VDC (typically, a fluctuating 1.5 to 3.5 volts reading to C; at least 0.25 volts higher than -) SA BUS communication circuit to optional economizer board, 4-stage board, fault detection & diagnostics board, netstat and/or <b>MAP-Gateway</b>
<b>Temperature Sensor connections at right upper edge of 4-Stage Board</b>		
CC3+	#3 refrigerant circuit Condenser Coil temperature sensor input from 10K $\Omega$ @ 77°F, Type III negative temperature coefficient thermistor	Input required for heat pump units, not required for A/C units; 3.625 VDC reading CC3+ to CC3- with open circuit. Used in heat pump demand defrost calculation.
EC3+	#3 refrigerant circuit Evaporator Coil temperature sensor input from 10K $\Omega$ @ 77°F, Type III negative temperature coefficient thermistor	Input required for operation; 3.625 VDC reading EC3+ to EC3- with open circuit. Used in suction line temperature safety.

**Table 27: 4-Stage Board (Continued)**

Terminal	Description	Function and Comments
CC4+	#4 refrigerant circuit Condenser Coil temperature sensor input from 10K $\Omega$ @ 77°F, Type III negative temperature coefficient thermistor	Input required for heat pump units, not required for A/C units; 3.625 VDC reading CC4+ to CC4– with open circuit. Used in heat pump demand defrost calculation.
EC4+	#4 refrigerant circuit Evaporator Coil temperature sensor input from 10K $\Omega$ @ 77°F, Type III negative temperature coefficient thermistor	Input required for operation; 3.625 VDC reading EC4+ to EC4– with open circuit. Used in suction line temperature safety.
AUX-2+	Not Used	Not Used
AUX-1+	Not Used	Not Used
<b>Quick Connect on right hand side</b>		
COM	Common for Modbus connection to staged heat board	Future
MB_B	Terminal B for Modbus connection to staged heat board	Future
MB_A	Terminal A for Modbus connection to staged heat board	Future
C	Common for HW Valve connection	0-10VDC
HWV	Analog out for HW Valve	0-10VDC
VAV	VAV box Common relay contact	Used to interlock the VAV boxes with RTU morning warm-up
BOX	VAV box normally open relay contact	Used to interlock the VAV boxes with RTU morning warm-up
<b>Harness Connectors on right hand side of 4-stage Board</b>		
C	Common for analog outputs	Future
HGR MOD	0-10VDC analog output for hot gas reheat	Future
C1 MOD	0-10VDC analog output for C1 modulation	Future
CF1 MOD	0-10VDC analog output for Condenser Fan 1 modulation	Future
CF2 MOD	0-10VDC analog output for Condenser Fan 2 modulation	Future
<b>Terminal at lower right corner of 4-stage Board</b>		
24V FOR OUTPUTS	24 VAC hot for C3, C4, CF2, H3, and HGR	Output relay circuitry is isolated from other 4-stage components and the 24 VAC hot source may be from a second transformer in the unit
<b>Cool and Heat section connections on lower right edge of 4-stage board</b>		
C3	24 VAC hot output for compressor 3	If demand is present and permissions allow compressor 3 operation
C4	24 VAC hot output for compressor 4	If demand is present and permissions allow compressor 4 operation
CF2	24 VAC hot output for the condenser fan contactor coil	Output with either C3 or C4 output.
H3	24 VAC hot output for heat section stage 3	Not effective for cooling-only units. Output if demand is present and permissions allow heat section operation
HGR	24 VAC hot output for hot gas reheat	Future
<b>Refrigerant circuit safety switches at lower left of 4-stage board</b>		
LPS3 (Right Pin)	24 VAC hot out for refrigerant circuit 3 Low Pressure Switch	Connects through circuit trace to the left HSP3 pin
LPS3 (Left Pin)	24 VAC hot return from refrigerant circuit 3 Low Pressure Switch	Input is only considered after 30 seconds of C3 output; afterwards, input must be present to allow C3 output. Three LPS3 trips in a one hour period cause a "Low Pressure Switch 3 Lockout" and C3 output is then prevented until alarm reset.
HPS3 (Right Pin)	24 VAC hot out for refrigerant circuit 3 High Pressure Switch	Connects through circuit trace to the R terminal

Table 27: 4-Stage Board (Continued)

Terminal	Description	Function and Comments
HPS3 (Left Pin)	24 VAC hot return from refrigerant circuit 3 High Pressure Switch	Input is only considered if C3 output is needed; input must be present to allow C3 output. Three HPS3 trips in a two hour period cause a "High Pressure Switch 3 Lockout" and C3 output is then prevented until alarm reset. Connects through circuit trace to the right LPS3 pin.
LPS4 (Right Pin)	24 VAC hot out for refrigerant circuit 4 Low Pressure Switch	Connects through circuit trace to the left HSP4 pin
LPS4(Left Pin)	24 VAC hot return from refrigerant circuit 4 Low Pressure Switch	Input is only considered after 30 seconds of C4 output; afterwards, input must be present to allow C4 output. Three LPS4 trips in a one hour period cause a "Low Pressure Switch 4 Lockout" and C4 output is then prevented until alarm reset.
HPS4 (Right Pin)	24 VAC hot out for refrigerant circuit 4 High Pressure Switch	Connects through circuit trace to the R terminal
HPS4 (Left Pin)	24 VAC hot return from refrigerant circuit 4 High Pressure Switch	Input is only considered if C4 output is needed; input must be present to allow C4 output. Three HPS4 trips in a two hour period cause a "High Pressure Switch 4 Lockout" and C4 output is then prevented until alarm reset. Connects through circuit trace to the right LPS4 pin.
<b>Heat safety circuit on left side of 4-stage board</b>		
LIM2	Monitored 24 VAC input through heat section limit switch(es)	If voltage is absent, indicating the heat section is over temperature, the UCB will bring on the indoor blower
GV2	24 VAC hot input confirming heat section operation	Sourced from gas valve 2 in gas heat units or second stage heat contactor in electric heat units. Input within 5 minutes from initiation of H2 output initiates the "Heat On Fan Delay" timer, loss of input following the termination of H2 output initiates the "Heat On Fan Delay" timer, no input within 5 minutes from initiation of H2 output initiates an "Ignition Failure" alarm, input for longer than 5 minutes without H2 output initiates a "Gas Valve Mis-wire" alarm
LIM3	Monitored 24 VAC input through heat section limit switch(es)	If voltage is absent, indicating the heat section is over temperature, the UCB will bring on the indoor blower
GV3,4	24 VAC hot input confirming heat section operation	
<b>Hot water safety quick connects on left side of 4-stage board</b>		
FS HWR	Flow switch for Hydronic heat – 24VAC hot output	Flow switch interlock for hot water coil
FS HW	Flow switch for Hydronic heat – 24VAC hot return	Flow switch interlock for hot water coil
<b>Thermostat Inputs on left side of 4-stage board</b>		
Y3	3rd stage cooling request, 24 VAC input switched from R	Visible in the display menu when the #ClgStgs parameter is set for 4, also effective for economizer free cooling supply air temperature reset when the #ClgStgs parameter is set for 4
Y4	4th stage cooling request, 24 VAC input switched from R	Visible in the display menu when the #ClgStgs parameter is set for 4, also effective for economizer free cooling supply air temperature reset when the #ClgStgs parameter is set for 4
W3	3rd stage heating request, 24 VAC input switched from R	Not effective for cooling-only units

**Start-Up Sheet****START-UP & SERVICE DATA INSTRUCTION****COMMERCIAL PACKAGE UNITS****3.0 To 40.0 TONS****START-UP CHECKLIST**

Date: \_\_\_\_\_

Job Name: \_\_\_\_\_

Customer Name: \_\_\_\_\_

Address: \_\_\_\_\_

City: \_\_\_\_\_ State: \_\_\_\_\_ Zip: \_\_\_\_\_

Model Number: \_\_\_\_\_ Serial Number: \_\_\_\_\_

Qualified Start-up Technician: \_\_\_\_\_ Signature: \_\_\_\_\_

HVAC Contractor: \_\_\_\_\_ Phone: \_\_\_\_\_

Address: \_\_\_\_\_

Contractor's E-mail Address: \_\_\_\_\_

Electrical Contractor: \_\_\_\_\_ Phone: \_\_\_\_\_

Distributor Name: \_\_\_\_\_ Phone: \_\_\_\_\_

**WARRANTY STATEMENT**

Johnson Controls/UPG is confident that this equipment will operate to the owner's satisfaction if the proper procedures are followed and checks are made at initial start-up. This confidence is supported by the 30 day dealer protection coverage portion of our standard warranty policy which states that Johnson Controls/UPG will cover parts and labor on new equipment start-up failures that are caused by a defect in factory workmanship or material, for a period of 30 days from installation. Refer to current standard warranty policy and warranty manual found on UPGnet for details.

In the event that communication with Johnson Controls/UPG is required regarding technical and/or warranty concerns, all parties to the discussion should have a copy of the equipment start-up sheet for reference. A copy of the original start-up sheet should be filed with the Technical Services Department.

The packaged unit is available in constant or variable air volume versions with a large variety of custom options and accessories available. Therefore, some variation in the startup procedure will exist depending upon the products capacity, control system, options and accessories installed.

This start-up sheet covers all startup check points common to all package equipment. In addition it covers essential startup check points for a number of common installation options. Depending upon the particular unit being started not all sections of this startup sheet will apply. Complete those sections applicable and use the notes section to record any additional information pertinent to your particular installation.

Warranty claims are to be made through the distributor from whom the equipment was purchased.

**EQUIPMENT STARTUP**

**Use the local LCD or Mobile Access Portal (MAP) Gateway to complete the start-up.**

**A copy of the completed start-up sheet should be kept on file by the distributor providing the equipment and a copy sent to:**

Johnson Controls/UPG  
Technical Services Department  
5005 York Drive  
Norman, OK 73069

1034349-UCL-C-0315

**SAFETY WARNINGS**

The inspections and recording of data outlined in this procedure are required for start-up of Johnson Controls/UPG's packaged products. Industry recognized safety standards and practices must be observed at all times. General industry knowledge and experience are required to assure technician safety. It is the responsibility of the technician to assess all potential dangers and take all steps warranted to perform the work in a safe manner. By addressing those potential dangers, prior to beginning any work, the technician can perform the work in a safe manner with minimal risk of injury.

<b>▲ WARNING</b>
Lethal voltages are present during some start-up checks. Extreme caution must be used at all times.

<b>▲ WARNING</b>
Moving parts may be exposed during some startup checks. Extreme caution must be used at all times.

**NOTE:** Read and review this entire document before beginning any of the startup procedures.

**DESIGN APPLICATION INFORMATION**

This information will be available from the specifying engineer who selected the equipment. If the system is a VAV system the CFM will be the airflow when the remote VAV boxes are in the

full open position and the frequency drive is operating at 60 HZ. **Do not proceed with the equipment start-up without the design CFM information.**

Design Supply Air CFM: \_\_\_\_\_ Design Return Air CFM: \_\_\_\_\_

Design Outdoor Air CFM At Minimum Position: \_\_\_\_\_

Total External Static Pressure: \_\_\_\_\_

Supply Static Pressure: \_\_\_\_\_

Return Static Pressure: \_\_\_\_\_

Design Building Static Pressure: \_\_\_\_\_

Outside Air Dilution: Economizer Position Percentage: \_\_\_\_\_ CFM: \_\_\_\_\_

Supply Gas Pressure After Regulator W/o Heat Active \_\_\_\_\_ Inches \_\_\_\_\_

ADDITIONAL APPLICATION NOTES FROM SPECIFYING ENGINEER:

1034349-UCL-C-0315

**REFERENCE**

<b>General Inspection</b>	<b>Completed</b>	<b>See Notes</b>
Unit inspected for shipping, storage, or rigging damage	<input type="checkbox"/>	<input type="checkbox"/>
Unit installed with proper clearances	<input type="checkbox"/>	<input type="checkbox"/>
Unit installed within slope limitations	<input type="checkbox"/>	<input type="checkbox"/>
Refrigeration system checked for gross leaks (presence of oil)	<input type="checkbox"/>	<input type="checkbox"/>
Terminal screws and wiring connections checked for tightness	<input type="checkbox"/>	<input type="checkbox"/>
Filters installed correctly and clean	<input type="checkbox"/>	<input type="checkbox"/>
Economizer hoods installed in operating position	<input type="checkbox"/>	<input type="checkbox"/>
Condensate drain trapped properly, refer to Installation Manual	<input type="checkbox"/>	<input type="checkbox"/>
Economizer damper linkage tight	<input type="checkbox"/>	<input type="checkbox"/>
Gas Heat vent hood installed	<input type="checkbox"/>	<input type="checkbox"/>
All field wiring (power and control) complete	<input type="checkbox"/>	<input type="checkbox"/>

<b>Air Moving Inspection</b>	<b>Completed</b>	<b>See Notes</b>
Alignment of drive components	<input type="checkbox"/>	<input type="checkbox"/>
Belt tension adjusted properly	<input type="checkbox"/>	<input type="checkbox"/>
Blower pulleys tight on shaft, bearing set screws tight, wheel tight to shaft	<input type="checkbox"/>	<input type="checkbox"/>
Pressure switch or transducer tubing installed properly	<input type="checkbox"/>	<input type="checkbox"/>

<b>Exhaust Inspection</b> Powered <input type="checkbox"/> Barometric Relief <input type="checkbox"/>	<b>Completed</b>	<b>See Notes</b>
Check hub for tightness	<input type="checkbox"/>	<input type="checkbox"/>
Check fan blade for clearance	<input type="checkbox"/>	<input type="checkbox"/>
Check for proper rotation	<input type="checkbox"/>	<input type="checkbox"/>
Check for proper mounting (screen faces towards unit)	<input type="checkbox"/>	<input type="checkbox"/>
Prove operation by increasing minimum setting on economizer	<input type="checkbox"/>	<input type="checkbox"/>

<b>Economizer Inspection</b> Standard <input type="checkbox"/> BAS <input type="checkbox"/>	<b>Completed</b>	<b>See Notes</b>
CO <sub>2</sub> sensor installed Yes <input type="checkbox"/> No <input type="checkbox"/>	<input type="checkbox"/>	<input type="checkbox"/>
Check economizer setting (Reference SSE Control Board LCD menu location)	<input type="checkbox"/>	<input type="checkbox"/>
Prove economizer open/close through SSE Board Setting	<input type="checkbox"/>	<input type="checkbox"/>

<b>Reheat Mode</b> Normal <input type="checkbox"/> or Alternate <input type="checkbox"/> Not Applicable <input type="checkbox"/>
Humidity Sensor (2SH0401) _____

**Operating Measurements - Air Flow**

Fan operates with proper rotation	ID Fans <input type="checkbox"/>	Exh. Fans <input type="checkbox"/>	Cond. Fans <input type="checkbox"/>
Pressure drop across dry evaporator coil (At maximum design CFM) <sup>1</sup>			IWC
External Static Pressure			IWC
Return Static Pressure			IWC
Supply Static Pressure			IWC
Supply Air CFM Using Dry Coil Chart			CFM
Final Adjusted Supply Air CFM <sup>2</sup>			CFM

1. Consult the proper airflow to pressure drop table to obtain the actual airflow at the measured pressure differential.
2. Was a motor pulley adjustment or change required to obtain the correct airflow?  
 Was it necessary to increase or decrease the airflow to meet the design conditions?  
 If the motor pulley size was changed, measure the outside diameters of the motor and blower pulleys and record those diameters here;

Blower Motor HP \_\_\_\_\_ FLA \_\_\_\_\_ RPM \_\_\_\_\_

Pulley Pitch Diameter \_\_\_\_\_ Turns Out \_\_\_\_\_ Final Turns Out \_\_\_\_\_

Blower Pulley Pitch Diameter \_\_\_\_\_ Fixed Sheave \_\_\_\_\_

**ELECTRICAL DATA**

T1 - T2 \_\_\_\_\_ Volts                      T2 - T3 \_\_\_\_\_ Volts  
 Control Voltage \_\_\_\_\_ Volts                      T1 - T3 \_\_\_\_\_ Volts

Device	Nameplate	Measured List All Three Amperages
Supply Fan Motor <sup>1,2</sup>	AMPS	AMPS
Exhaust Motor (Dampers 100%)	AMPS	AMPS
Condenser Fan #1	AMPS	AMPS
Condenser Fan #2 (if equipped)	AMPS	AMPS
Condenser Fan #3 (if equipped)	AMPS	AMPS
Condenser Fan #4 (if equipped)	AMPS	AMPS
Compressor #1	AMPS	AMPS
Compressor #2 (if equipped)	AMPS	AMPS
Compressor #3 (if equipped)	AMPS	AMPS
Compressor #4 (if equipped)	AMPS	AMPS

1. VAV units with heat section - simulate heat call to drive VAV boxes and VFD/IGV to maximum design airflow position.
2. VAV units without heat section - VAV boxes must be set to maximum design airflow position.

1034349-UCL-C-0315

**OPERATING MEASUREMENTS - COOLING**

Stage	Discharge Pressure	Discharge Temp.	Liquid Line Temp. <sup>1</sup>	Subcooling <sup>2</sup>	Suction Pressure	Suction Temp.	Superheat
First	#	°	°	°	#	°	°
Second (if equipped)	#	°	°	°	#	°	°
Third (if equipped)	#	°	°	°	#	°	°
Fourth (if equipped)	#	°	°	°	#	°	°
Reheat 1st Stage	#	°	°	°	#	°	°

- 1. Liquid temperature should be taken before filter/drier.
- 2. Subtract 10 psi from discharge pressure for estimated liquid line pressure

Outside air temperature	_____ °F db	_____ °F wb	_____ %RH
Return Air Temperature	_____ °F db	_____ °F wb	_____ %RH
Mixed Air Temperature	_____ °F db	_____ °F wb	_____ %RH
Supply Air Temperature	_____ °F db	_____ °F wb	_____ %RH

**REFRIGERANT SAFETIES**

Action	Completed	See Notes
Prove Compressor Rotation (3 phase only) by gauge pressure	<input type="checkbox"/>	<input type="checkbox"/>
Prove High Pressure Safety, All Systems	<input type="checkbox"/>	<input type="checkbox"/>
Prove Low Pressure Safety, All Systems	<input type="checkbox"/>	<input type="checkbox"/>

**OPERATING MEASUREMENTS - GAS HEATING**

Fuel Type:       Natural Gas                                       LP Gas

Action	Completed	See Notes
Check for gas leaks	<input type="checkbox"/>	<input type="checkbox"/>
Prove Ventor Motor Operation	<input type="checkbox"/>	<input type="checkbox"/>
Prove Primary Safety Operation	<input type="checkbox"/>	<input type="checkbox"/>
Prove Auxiliary Safety Operation	<input type="checkbox"/>	<input type="checkbox"/>
Prove Rollout Switch Operation	<input type="checkbox"/>	<input type="checkbox"/>
Prove Smoke Detector Operation	<input type="checkbox"/>	<input type="checkbox"/>
Manifold Pressure	Stage 1	IWC <input type="checkbox"/>
	Stage 2 (If Equipped)	IWC <input type="checkbox"/>
	Stage 3 (If Equipped)	IWC <input type="checkbox"/>
Supply gas pressure at full fire		IWC <input type="checkbox"/>
Check temperature rise <sup>1</sup>	<input type="checkbox"/> measured at full fire	°F <input type="checkbox"/>

1.  $\text{Input X Eff. (BTU output)}$   
 $1.08 \text{ X Temp. Rise}$



## OPERATIONAL MEASUREMENTS - STAGING CONTROLS

<b>Verify Proper Operation of Heating/Cooling Staging Controls</b>	
Create a cooling demand at the Thermostat, BAS System or Simplicity SE Verify that cooling/economizer stages are energized.	<input type="checkbox"/>
Create a heating demand at the Thermostat, BAS System or Simplicity SE Verify that heating stages are energized.	<input type="checkbox"/>
<b>Verify Proper Operation of the Variable Frequency Drive (If Required)</b>	
Verify that motor speed modulates with duct pressure change.	<input type="checkbox"/>

### FINAL - INSPECTION

Verify that all operational control set points have been set to desired value Scroll through all setpoints and change as may be necessary to suit the occupant requirements.	<input type="checkbox"/>
Verify that all option parameters are correct Scroll through all option parameters and ensure that all installed options are enabled in the software and all others are disabled in the software. (Factory software settings should match the installed options)	<input type="checkbox"/>
Verify that all access panels have been closed and secured	<input type="checkbox"/>

### OBSERVED PRODUCT DEFICIENCIES & CONCERNS:

---

---

---

---

---

---

---

---

---

---

---

---

---

---

---

---

---

---

---

---

---

---

---

---